



承认书



SPECIFICATION FOR APPROVAL

客户名称 (CUSTOMER): RCS

客户料号 (CLIENT P/N): _____

客户品名 (DESCRIPTION): _____

金华升品名 (MODEL): RS-06/12-S335

日期 (DATE): 2011-1-4

承认书 APPROVED SIGNATURES					
客户承认 (CUSTOMER APPROVAL)			金华升公司承认 (RS APPROVAL)		
批准 AUTHORIZED BY	审核 RECHECKED BY	承认 APPROVAL BY	批准 AUTHORIZED BY	审核 RECHECKED BY	拟制 WRITE BY

客户确认签字、盖章后请回传一份承认书给我司./ Please return to us one copy of "SPECIFICATION FOR APPROVAL" with you approved signature.

深圳市金华升电源技术有限公司
 SHENZHEN JINHUASHENG POWER TECHNOLOGY CO., LTD.
 (H.K.RISING SUN TECHNOLOGY DEVELOPMENT LIMITED)
 中国广东省深圳市宝安区观澜桂花庙溪工业区广场路6号
 NO.6 Plaza Road, Guihua Miaoxi Industrial Park, Guanlan, Baoan,
 Shenzhen, Guangdong, China
 Tel: +86-755-27980417 Fax: +86-755-27980226
 Web: www.rs-power.com P.C.: 518110



目 录/Contents

变更履历表.....	3
1. 导言 Introduction.....	4
1.1 电源概况 Power Supply Overview.....	4
1.2 描述 Description.....	4
2. 电气规格 Electrical Specification	4
2.1 输入电压 Input Voltage.....	4
2.2 输入频率 Input Frequency	4
2.3 冲击电流 Inrush Current	4
2.4 最大输入电流 Input Current Limiting	4
2.5 效率 Efficiency	4
2.6 输出电压范围 DC Output voltage range	5
2.7 输出电流 DC Output Current.....	5
2.8 输出纹波与噪声 Output Ripple and Noise	5
2.9 电压过冲 Overshoot at turn-on/ turn-off.....	5
2.10 过压保护 Over Voltage Protection.....	5
2.11 短路保护 Short Circuit Protection.....	6
2.12 过流保护 Over Current Protection	6
2.13 保持时间 Hold up Time	6
2.14 启动时间 Start up Time.....	6
3 环境要求 Environment Requirement	6
3.1 温度 Temperature.....	6
3.2 湿度 Humidity	6
4 可靠性 Reliability.....	7
4.1 平均无故障间隔时间 MTBF	7
4.2 老化寿命测试 Burn-in and Life test	7
5 产品安规要求 Product Safety Requirement	7
5.1 标准 Standard	7
5.2 安规认证	7
5.3 泄漏电流 Leakage Current	7
5.4 绝缘强度 Dielectric Strength Testing.....	7
5.5 绝缘阻抗 Insulation Resistance.....	8
6 外观结构图 Case Mechanical Dimensions	8
7 铭牌 Label	8
8 包装 Packing	9
9 主要测试设备 Major Test Equipment	9
10 出货检验标准 Inspection Standards	9



变更履历表 Revision History

承认书版本 Spec. Edition	发行日期 Issue Date	修改内容 Modified content	产品版本 Product Edition
A.0		初版 Initial	V1.0



1. 引言 Introduction

1.1 电源概况 Power Supply Overview

这份规格书定义了 72 W 的电源适配器的功能需求，此电源将市电变换为 1 组稳定、连续的直流电压输出，并符合 ROHS 标准。

This specification defines 72 W power adapter functional requirements, the power adapter transformed a AC into stable, continuous DC voltage output, And the power supply shall meet the RoHS requirements.

1.2 描述 Description

- | | |
|--|---|
| <input type="checkbox"/> 插墙式适配器 SMPS Adaptor(Wall mount) | <input checked="" type="checkbox"/> 桌面型适配器 SMPS Adaptor(Desk-top) |
| <input type="checkbox"/> 开放式结构 Open Frame | <input type="checkbox"/> 带铁壳型 SMPS Unit (With Case) |
| <input type="checkbox"/> 其他 Others | |

2. 电气规格 Electrical Specification

2.1 输入电压 Input Voltage

工作电压范围为 90V-264V~，额定工作电压为 100V-240V~，在 2.7 定义负载范围下，电源能正常工作并符合所有电气特性。

Operating voltage range 90-264V~, rated operating voltage 100-240V~, the power shall work normally and meet all electrical requirements as per the load range specified in section 2.7.

2.2 输入频率 Input Frequency

交流输入电压频率范围 47-63Hz./Input AC voltage frequency range 47-63Hz.

额定交流输入电压频率 50/60Hz./Input rated AC voltage frequency range 50/60Hz.

2.3 冲击电流 Inrush Current

冲击电流峰值在额定输入电压，冷启动（25℃）时，不大于 50A；且在任何负载和输入条件下，不导致永久性损坏或危险，输入电压的定义 2.1 节。

Peak inrush current shall be limited to 50 A while the cold start at 25 degrees C and rated input voltage, and shall not result in a permanent damage of the power supply under any conditions of load and input voltage as specified at any input voltage in section 2.1.

2.4 最大输入电流 Input Current Limiting

在输入电压最小值，负载为满载条件下，最大输入电流不大于 2 A。

The input current should be less than 2 A, under minimum AC input and full loads.

2.5 效率 Efficiency

在额定输入电压，额定负载条件下，电源的效率大于 80 %；空载输入功率 ≤ 0.5W。

The power supply efficiency shall be greater than 80 % under rated input voltage. It will be measured at the typical load; no load input watt ≤ 0.5W.



2.6 输出电压范围 DC Output voltage range

12V 11.4V—12.8V (在适配器的输出线材的端子上测量)

12V 11.4V—12.8V (measure the terminal of output wire in the adapter)

2.7 输出电流 DC Output Current

表格 1: 输出电流限值

Table 1: DC output current limits

Output 输出	Min. 最小值	Max. 最大值	Unit 单位
6	0	6	A

2.8 输出纹波与噪声 Output Ripple and Noise

下面表格 2 是纹波与噪声要求, 以 2.6 节中定义的负载范围和 2.1 节定义的输入电压为测试条件, 纹波与噪声均应符合要求, 测试时示波器设置为 20MHz 带宽, 输出端并接一 0.1uF 瓷片电容和一 10uF 钽电解电容 (低 ESR 值)。

The following table 2 is output ripple and noise requirements, it will be met throughout the load ranges specified in Section 2.6 and under all input voltage conditions as specified Section 2.1, Measurements will be made with an oscilloscope set to 20MHz bandwidth limit. The outputs will be bypassed with one 0.1uF multilayer (type X7R) and one 10uF tantalum electrolytic (low ESR) capacitors.

表格 2: 纹波与噪声限值

Table 2: Output ripples and noise limits

Output 输出	最大值 Max.
≤ 120MV	120MV

2.9 电压过冲 Overshoot at turn-on/ turn-off

开机或关机时, 电压过冲不得超过标称值的 110%。

Any overshoot at turn on or turn off shall be less than 110% of rated output voltage.

2.10 过压保护 Over Voltage Protection

电源提供的过压保护, 详细定义如下表:

The power supply will provide over voltage protection function as defined below.

表格 3: 过压保护限值

Table 3: Over Voltage Protection limits

Output 输出	Min. 最小	Max 最大值	Unit 单位
12V	14.3	15.8	V



2.11 短路保护 Short Circuit Protection

电源输出的短路将自动进入保护状态，在保护过程中，不会出现诸如元器件、连接器等损坏危险，断开短路后，电源将自动恢复正常。

An output short circuit will automatically enter the protected status. The power supply will protect without damage to overseers of to the unit (components, connectors, etc) under the protection of process.

2.12 过流保护 Over Current Protection

电源过流点符合下表限值要求，而且过流保护无任何危险和损坏，在保护去除后，电源要断开 AC 输入让电容放电完后方能恢复其功能。

The power supply shall meet the limitation requirement as below table without any damage, the unit shall recover the function after the protection is removed.

表格 4: 过流保护限值

Table 4: Over Current Protection limits

Output 输出	Min. 最小	Max 最大值	Unit 单位
6	7.2	12	A

2.13 保持时间 Hold up Time

满载条件下，电源在 100 Vac 输入时，保持时间不小于 10 mS。

Hold-up time no less than 10 mS at 100 Vac input, the output loading should be set up with full load during the test.

2.14 启动时间 Start up Time

满载条件下，电源在 110 Vac 输入时，启动时间不大于 3 秒。

Start up time no more than 3 seconds at 110 Vac input, the output loading should be set up with full load during the test.

3 环境要求 Environment Requirement

3.1 温度 Temperature

工作环境温度: 0+40 °C

Operating Ambient: 0+40 °C

贮存环境温度: -20+75 °C

Non-operating Ambient: -20+75 °C

3.2 湿度 Humidity

工作时: 20%-85% 相对湿度 (非冷凝)

Operating: 20%-85% relative humidity (Non- condensing)

贮存时: 10%-90% 相对湿度 (非冷凝)

Non-operating: 10%-90% relative humidity (Non- condensing)



4 可靠性 Reliability

4.1 平均无故障间隔时间 MTBF

25℃环境温度，满载条件，额定电压输入条件，平均无故障间隔时间 \geq 10000 小时(MIL-HDBK-217F)。(可根据客户要求设计为 50000 小时)

MTBF no less than 10000 hours (25 degrees C, Full load and rated voltage input, MIL-HDBK-217F) (we can design MTBF for 50000hours if customer request.)

4.2 老化寿命测试 Burn-in and Life test

公司将与客户评估并确认电源产品室内老化寿命测试过程。

Company shall discuss with customer to make sure the power in house Burn-In and life test procedures.

5 产品安规要求 Product Safety Requirement

5.1 标准 Standard

遵循 IEC60950、EN55022 EN 60950-1 要求。

Meet IEC60950、EN55022 EN 60950-1 standard requirement.

5.2 安规认证

类型/Type	国家/Country	类型/Type	国家/Country
<input type="checkbox"/> UL/CUL	美国/USA	<input type="checkbox"/> CCC	中国/China
<input type="checkbox"/> TUV/GS	欧洲/Europe	<input type="checkbox"/> PSE	日本/Japan
<input type="checkbox"/> FCC	美国/USA	<input type="checkbox"/> CB	欧洲/Europe
<input checked="" type="checkbox"/> CE	欧洲/Europe	<input type="checkbox"/> C-TICK/SAA	澳洲/Australia
<input type="checkbox"/> IRAM	阿根廷/Argentina	<input type="checkbox"/> EK	韩国/Korea
<input type="checkbox"/> MEPS	澳洲/Australia	<input checked="" type="checkbox"/> BSMI	台湾/Taiwan

5.3 泄漏电流 Leakage Current

在输入 240Vac/50Hz 的条件下泄漏电流不得超过 0.25 mA 。

Leakage current shall not exceed 0.25 mA under 240Vac / 50Hz input condition.

5.4 绝缘强度 Dielectric Strength Testing

绝缘强度满足下表的要求，100% 在线产品执行此项测试，并每一项目至少保持 3S 时间，无任何故障。

Hi-pot test shall be met the table 5 requirements, an item listing this test as a 100% production test must be performed and be maintained at that level for a minimum of 3seconds without failure.

表 5: 耐压测试 Table 5: Hi-pot test

项目 Item	规格要求 Specification	备注 Remark
输入----输出 Primary to Secondary	1.5KVac < 10mA	
输入----地 Primary to P.G	-	无飞弧 No arcing 无击穿 No broken
输出----地 Secondary to P.G	-	

5.5 绝缘阻抗 Insulation Resistance

初级对次级: $\geq 50M$ 欧姆, 500VDC

-Primary to Secondary: 10 Meg. Ohms min. 500VDC

初级对地: $\geq 50M$ 欧姆, 500VDC

-Primary to P.G: 10 Meg. Ohms min. 500VDC

6 外观结构图 Case Mechanical Dimensions



长*宽*高=**141mm** *60.5mm *34mm

输出线材(公差 $\pm 50MM$)

输出线材: 长度 $L=1200\pm 50MM$;

线材规格: 18# 1185 黑色 圆线 带磁环 圆尾卡;

插头规格: 外径*内径*深度 = $\Phi 5.5*\Phi 2.1*10.5mm$ 音叉自锁 直头

7 铭牌: ----

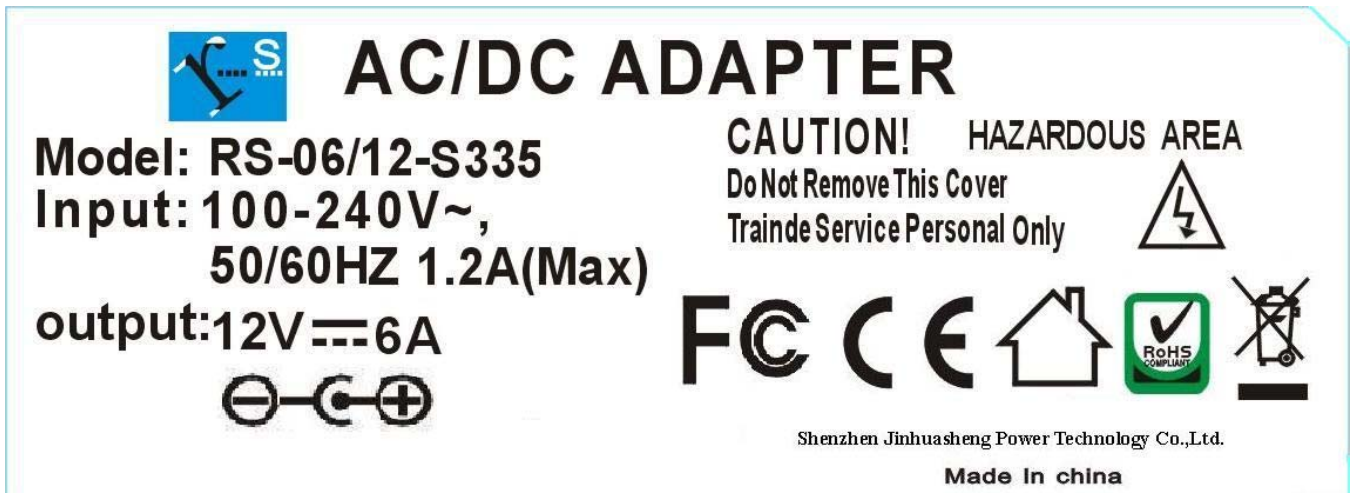

8 包装 Packing

若客户未提出包装方式时，均使用金华升公司之包装方式

Unless specially requirement of customer, the packing according to RS company style.

8.1 内包装: PE袋

Inner package: PE bag

8.2 外包装: 纸箱

Outer package: paper-box.

8.3 外包装箱标识: 客户、订单号、品名、数量、日期等信息

Outer package notes include the information: Customer Name, LOT Number, Model No., Date, and so on.

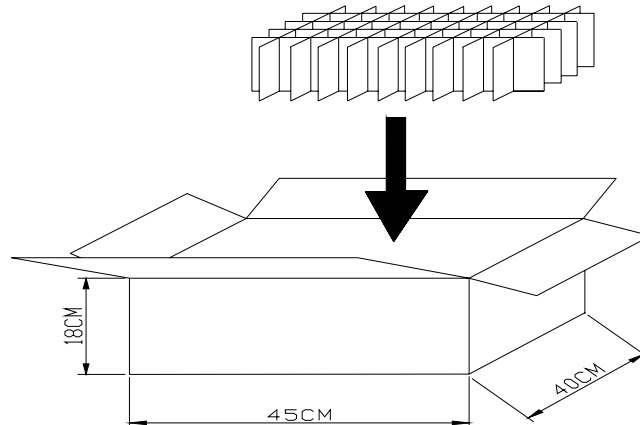

9 主要测试设备 Major Test Equipment

9-1 交流输入电源 AC SOURCE

9-2 电源功率计/ POWER METER

9-3 电子负载/ ELECTRONIC LOAD

9-4 示波器/ OSCILLOSCOPE

9-5 万用表/ MULTIMETER

9-6 直流输入电源/ DC POWER

9-7 耐压测试仪/ HI-POT TESTER

9-8 多路温度测试仪/Multi-routes temperature test instrument

10 出货检验标准 Inspection Standards

表格 8 出货检验要求 Table 8 Inspection Requirement

NO.	检查项目 Test project	检验标准 Test standard	抽样水准 Sample Level	检验水准 Test standard
1	电气性能 Performance	MIL-STD-105E	II	严重缺点: CR=0 Serious defect: CR=0
2	尺寸 Size			主要缺点: AQL=0.4 Main defect: AQL=0.4
3	外观、包装 Shell, Package			次要缺点: AQL=1.0 Petit defect: AQL=1.0