

**AOYUE<sup>®</sup>**  
**HHL3000** *Reflow Oven*

INSTRUCTION MANUAL

Thank you for purchasing Aoyue HHL3000 Reflow Oven.  
It is important to read the manual before using the equipment.  
Please keep manual in accessible place for future reference.

**AOYUE TONGYI ELECTRONIC EQUIPMENT FACTORY**

Jishui Industrial Zone, Nantou, Zhongshan City,  
Guangdong Province, P. R. China

[www.aoyue.com](http://www.aoyue.com)

Copyright © 2007



This manual is designed to familiarize and instruct the technician with the proper operation and maintenance of the equipment. The "Care and Safety Precautions" section explains the hazards of using any type of soldering or reworking device. Please read carefully and observe the guidelines in order to maximize usage and minimize the risk of injury or accidents .

## OPERATING GUIDELINES

7. Press the "**START**" button again to return to the profile selection menu.
8. Repeat procedures "D" and "E" to continue working on boards using the same profile settings.

**NOTE:** Profile setting would need to be manually re-adjusted every time power is cut off from the system.

### **ATTENTION**

- Temperature settings presented in this manual are provided for reference purpose only. Please refer to device manufacturer data for the tolerances and characteristics of items to be soldered.
- Actual temperature settings for soldering and reworking are dependent on the size of the material to be soldered and solder paste reflow temperatures.
- Very high reworking temperatures can damage sensitive SMT materials.

## ERROR MESSAGES

1. Error messages occur when the temperature sensor detects over heat (over 250 °C) or when the unit detects temperature abnormalities (e.g., sensor does not detect rising temperatures or sensor is damaged). The display will show the detected temperatures while displaying the "**Err**" message.
2. Error messages will also occur if the connector for the control and sensor is not properly secured. Reconnect properly the sensor-main controls wire if this happens.
3. When an error message is displayed, press the ON/OFF button to exit from the current process and begin from the start. Turn off the entire unit then on again. If error message recurs:
  - Check the connection of the sensor-main control wire
  - Check the sensor inside the reflow system
  - Check the heating lamps.
  - Replace any defective parts as needed.

## OPERATING GUIDELINES

### E. STARTING/ENDING THE REFLOW PROCESS

1. While the display is showing the “**Prof 1**” screen, press the **SET** button to take us to Stage “**A**” and display our set duration for this stage.
2. Wait for the internal temperature to rise between the range 50 to 60°C. This temperature will be displayed on the top screen (1 from the panel).
3. When the display is between 50° to 60°C, start the reflow oven by pressing the **START** button (3 from the panel). The reflow oven would heat up and cool down based on the setting we indicated on profile 1.
5. After all five stages have finished, the display would show “**End**” indicating the entire process is completed. The upper display would still show the current internal temperature of the reflow oven.
6. Wait for the display to show a significantly low temperature before handling the contents. If it is desired to move the contents while hot, use appropriate tools or equipments to handle (hot) objects.

**NOTE:** The reflow oven has a normal cool down rate of approximately 2-3°C/s, any value significantly larger than this would render the oven unable to keep up with the cool down rate.

STAGE	A	E	F	P	L
Duration	130	80	70	70	99
Peak Temperature	130	170	195	220	58

**Profile 1** (default values)

STAGE	A	E	F	P	L
Duration	130	78	65	65	99
Peak Temperature	130	160	185	210	58

**Profile 2** (default values)

**WARNING:** Items can be very hot. Allow sufficient time for items to cool down before handling. Use proper equipment to handle hot objects.

## TABLE OF CONTENTS

Product Description .....	4
Package Inclusion .....	5
Installation/Setup .....	5
Specifications .....	6
Functions and Features .....	6
Safety Precautions .....	7
Control Panel Guide .....	8
Operating Guidelines .....	9 — 15
Initial Procedures	
Profile selection	
Profile setup	
Preparing the Board	
Start/End of reflow process	

## PRODUCT DESCRIPTION

The Aoyue HHL3000 Reflow Oven is a highly versatile equipment used for reflowing and preheating different SMT components and PCB. The system utilizes a microcontroller to effectively and efficiently manage the working temperature while facilitating the duration of the heating process. It has a bright LED display that clearly displays the time and temperature plus a fully digital control panel for monitoring and ease of use.

The system makes use of infrared (IR) heat wave technology to distribute heat evenly on the component and PCB. It has also an integrated temperature sensor that is positioned in such a way that the actual temperature measurement of the PCB and component is obtained. This provides effective measure to minimize damage to the board and its components due to thermal shock or low temperature level conditions.

## OPERATING GUIDELINES

**Cooling Stage** — The cooling rate of the solder joint after reflow is generally recommended to be very fast to allow smaller grain size of the solder. Otherwise, if the cooling rate is slow, increased grain size causing relatively weaker solder joints would result.

16. When the duration for stage "L" has been adjusted, press **SET** button.
17. The display will indicate the set peak temperature value required at the end of stage "L". The display will show "u058", which means the temperature would decrease until the set temperature of 58°C is reached at the end of stage "L". The set peak temperature can be adjusted by pressing the "+" and "-" buttons.

To compute for the falling slope rate of stage "L", subtract the temperature at the beginning of the stage "L" (which is approximately 220°C) from the peak temperature at the end of stage "L" (for this example 58°C). Divide the answer by the duration in seconds.

$$(58^{\circ}\text{C}-220^{\circ}\text{C})/70= -1.63^{\circ}\text{C/s.}$$

Therefore the slope rate of stage "L", is around -1.63°C/s.

18. Pressing the **SET** button would bring us back to "Prof 1" display. We can now start utilizing the reflow oven using our set parameters.

### **D. PREPARING THE BOARD**

1. Prepare the board to be reflowed.
2. Apply solder paste to the pads of the board.
3. Place the components to its proper footprint on the board.
4. Pull out the reflow oven tray and carefully place the board at the center of the tray.



**WARNING:** The tray could be very hot. Handle the tray with caution to avoid injury to personnel or damage to equipments.

5. Place the temperature sensor at the center of the board and make sure the thermal sensor tip is touching the board or the top of a component.
6. Push the drawer back to close the reflow oven.

## OPERATING GUIDELINES

To determine the rising slope rate of stage "F", subtract the temperature at the beginning of stage "F" (which is approximately 170°C) from the set peak temperature at the end of stage "F" (for this example 195°C). Divide the difference by the duration in seconds.

$$(195^{\circ}\text{C}-170^{\circ}\text{C})/70= 0.35^{\circ}\text{C}/\text{s}.$$

Therefore the slope rate of stage "F", is around 0.35°C/s.

12. Press the **SET** button again. The display would change to "P070", which means we are now in Stage "P". The duration for stage "P" is 70 seconds. Stage "P" can also be set as the **reflow stage**.

**WARNING:** Be extra careful when setting the temperature during reflow stage. Very high temperature may cause boards to char or burn. If the temperature is too low, cold solder joints will occur. The peak temperature in this zone should be sufficient enough for adequate flux action and obtain good wetting.

13. When the duration for stage "P" has been adjusted, press **SET** button.  
14. The display will indicate the set peak temperature value required at the end of stage "P". The display will show "o220", which means the temperature would slowly increase until the peak temperature of 220°C is reached at the end of stage "P". The set peak temperature can be adjusted by pressing the "+" and "-" buttons.

To compute for the rising slope rate of stage "P", subtract the temperature at the beginning of the stage "P" (which is approximately 195°C) from the peak temperature at the end of stage "P" (for this example 220°C). Divide the answer by the duration in seconds.

$$(220^{\circ}\text{C}-195^{\circ}\text{C})/70= 0.35^{\circ}\text{C}/\text{s}.$$

Therefore the slope rate of stage "P", is around 0.35°C/s.

15. Press the **SET** button again. The display would change to "L099", which means we are now in Stage "L". The duration for stage "L" is 99 seconds. Stage "L" can also be set as our **cooling stage**.

## PACKAGE INCLUSION

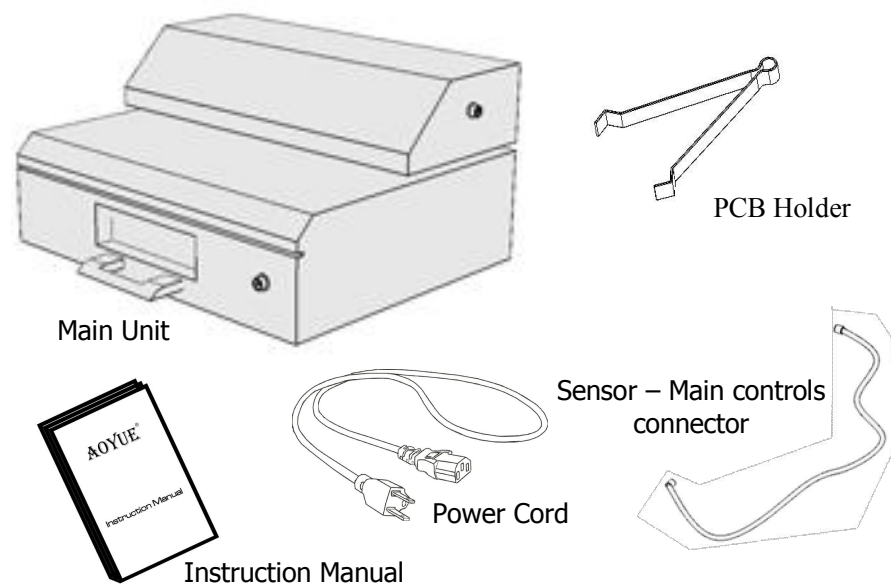

## INSTALLATION / INITIAL SETUP

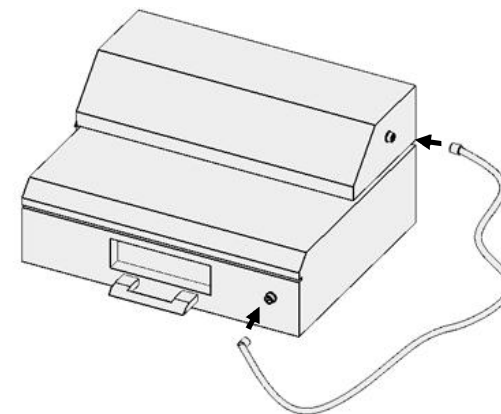

Connect the "Sensor-Main controls connector wire" to the receptacles found at the side of the main controls and front of the unit.

## SPECIFICATIONS

MAIN STATION	
Power Input	Available in 110V / 220V
Station Dimensions	360 (l) x 385 (w) x 190 (h) mm
Weight	3.5 Kgs.
Heating Power	1100W
Temperature Range	100°C - 250°C
Heating Element Type	Infrared
Valid Solder Area	210 mm x 190 mm
Standard reflow time	4 mins — 8 mins
Rising slope	0.01°C/s to 3 °C/s

## FUNCTIONS and FEATURES

- Microprocessor-controlled equipment.
- Direct PCB temperature measurement, improves accuracy and lessens damage or distortion.
- Five (5) temperature and time control points with automatic slope adjustment. Configurable to suit different solder paste and circuit boards.
- Two (2) default profiles suitable with most common solder paste specifications.
- Quick and easy resetting of control points for precise tuning of reflow profiles.
- Built-in safety feature of industry standard 0.01°C/s to 3°C/s rising slope.
- Fully digital panel controls and read-out of time and temperature for monitoring and ease of use.
- Highly compatible with lead-free applications.

## OPERATING GUIDELINES

The purpose of the **Soak Stage** is to bring the temperature across the entire board to a uniform level. The ramp rate in this stage should be very low. The temperature is now raised at around 150°C to 195°C. A very high temperature in this stage can cause solder splatter due to excessive oxidation of paste. The soak stage also acts as the flux activation zone for solder paste.

7. When the duration for stage "E" has been adjusted, press **SET** button.
8. The display will indicate the set peak temperature value required at the end of stage "E". The display will show "c170", which means the temperature would slowly increase until the peak temperature of 170°C is reached at the end of stage "E". The set peak temperature can be adjusted by pressing the "+" and "-" buttons.

To compute for the rising slope rate of stage "E", subtract the temperature at the beginning of the stage "E" (which is approximately 130°C) from the peak temperature at the end of stage "E" (for this example 170°C). Divide the difference by the duration in seconds.

$$(170^{\circ}\text{C}-130^{\circ}\text{C})/80= 0.5^{\circ}\text{C/s.}$$

Therefore, the slope rate of stage "E", is around 0.5°C/s.

9. Press the **SET** button again. The display would change to "F070", which means we are now in Stage "F". The duration for stage "F" is 70 seconds. Stage "F" can be set as continuation of soak stage **or** the start of the reflow stage. The default settings for Stage "F" is set as the continuation of the soak time and flux activation stage.
10. When the duration for stage "F" has been adjusted, press **SET** button.
11. The display will indicate the set peak temperature value required at the end of stage "F". The display will show "d195", which means the temperature would slowly increase until the peak temperature of 195°C is reached at the end of stage "F". The set peak temperature can be adjusted by pressing the "+" and "-" buttons.

## OPERATING GUIDELINES

**The Pre-Heat Stage** – Pre-heating is a requirement to avoid thermal shock to sensitive components and warping of the board. The appropriate temperature should be around 100°-130°C. During pre-heating, if the temperature increase rate is too fast (>3°C), the solder paste may explode and splatter causing solder balls which may then cause a short-circuit. Therefore, proper temperature setting should be observed.

3. With the display showing "**Prof 1**", press the **SET** button (5 from the panel). The display would show the default setting which is "**A130**" in the lower duration/time display window (2 from the control panel). The upper display (1 from the control panel) would show the current internal temperature.
4. The default duration for stage "**A**" is 130 seconds. Press **SET** when duration of stage "**A**" is adjusted.

**NOTE:** Always keep the drawer closed when setting the profile. This is required as the oven stabilizes the internal temperature to 50°C.

5. The display would change to the set peak temperature value that is required at the end of stage "**A**" (Pre-Heat stage). The display will show "**b130**", which means the temperature would slowly increase until the peak temperature of 130°C is reached at the end of stage "**A**". The set peak temperature can be adjusted by pressing the "+" or "-" buttons (6 or 7 from the panel).

To compute for the rising slope rate of this stage, subtract the temperature at the beginning of the stage "**A**" (which is approximately 50°C) from the peak temperature at the end of stage "**A**" (for this example 130°C). Divide the difference by the duration (in seconds).

$$(130^{\circ}\text{C}-50^{\circ}\text{C})/130= 0.6^{\circ}\text{C/s.}$$

Therefore the slope rate of this stage (stage "**A**", pre-heat stage ) is 0.6°C/s.

6. Press the **SET** button. The display would change to "**E080**", which means we are now in Stage "**E**". The duration for stage "**E**" is 80 seconds. Stage "**E**" is also normally set as our soak time.

## SAFETY PRECAUTIONS



**CAUTION:** Improper usage can cause serious injury to personnel and/or damage to equipment and work area. For your own safety, please observe the following precautions.

- Check each component after opening the package to make sure everything is in good condition. If there are any suspected damage, do not use the item and report the issue to your vendor.
- Turn OFF the main power switch and unplug the device from the main power source when moving the device from one location to another.
- Do not strike or subject the main unit (and all its components) to physical shock. Use carefully to avoid injury and damage to any part.
- Handle with care.
  - Never drop or sharply jolt the unit.
  - Contains delicate parts that may break if the unit is dropped.
- Make sure the equipment is always grounded. Always connect power to a grounded receptacle.
- Temperature may reach as high as 300°C when switched ON.
  - Do not use the device near flammable gases, paper and other flammable materials.
  - Do not touch heated parts, which can cause severe burns.
  - Do not touch metallic parts near the tip.
- Disconnect the plug from the main power source if the unit will not be used for a long period.
  - Power OFF the device during breaks, if possible.
- Use only genuine replacement parts.
  - Turn off power and let the unit cool down before replacing any part.
- The unit may produce a small amount of smoke and unusual odor during initial usage. This is due to the flux contained inside the solder paste. This is normal and should not yield any negative impact.
- Soldering process produces smoke — use on well ventilated places.
- Do not alter the unit, specifically the internal circuitry, in any manner.

## CONTROL PANEL GUIDE

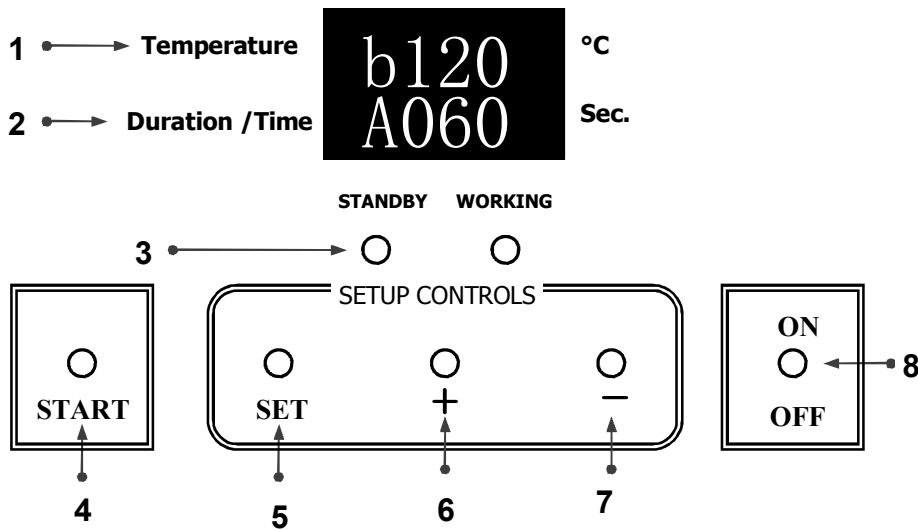

### LEGEND:

- 1 — Actual and Set Temperature display
- 2 — Timer and duration display
- 3 — Operation Lamp
- 4 — Start button
- 5 — Set button
- 6 — Increase button
- 7 — Decrease button
- 8 — On/Off button

### IMPORTANT REMINDERS:

1. Make sure the equipment is placed on a flat stable surface.
2. Ensure all function switches are OFF prior to reworking.
3. Ensure all terminal connections are properly secured.

## OPERATING GUIDELINES

**IMPORTANT:** Please refer to the **CONTROL PANEL GUIDE** page for buttons and display panel directory.

### A. INITIAL PROCEDURES

1. Make sure all function switches are deactivated and all terminal connections properly secured.
2. Plug the device to the main power source using the power cord provided in the package.
3. Switch the unit **ON** via the switch located at the back of the unit.
4. The display would show **AOYUE** briefly then revert to displaying **OFF**.

### B. PROFILE SELECTION

1. Follow initial procedures, "**A. INITIAL PROCEDURES**".
2. Press the ON/OFF button (8 from the control panel ).
3. The display would show "**Prof 1**", which means Profile 1 will be used.

**Profile 1** is preset with an estimated generic working reflow profile.  
**Profile 2** is preset for preheating boards for reworking. Components to be removed should be extracted before the cool down stage (last stage "L") goes into effect.

4. Pressing the increase or decrease buttons (6 and 7 from the control panel, respectively) would change the "**Prof 1**" to "**Prof 2**", which means profile 2 has been selected.
5. When the required profile is selected press SET (5 from control panel).

### C. PROFILE SETUP

1. Follow initial procedures, "**A. INITIAL PROCEDURES**".
2. **Setting up the pre-heat stage:** This stage is labeled as "**A**" at our profile panel with temperature at point "**b**" as the peak temperature reached when stage "**A**" is over.