

产品规格承认书

PRODUCT SPECIFICATION / APPROVAL SHEET

A. 一般规格 (General Specification)

項目 (Item)		規格 / 條件 (Specification / Condition)	
01	型号 (Part No.)	JD8025DC JD8025D24HB	
02	外型尺寸 (Outline Dimension)	80X80X25 mm	
03	额定电压 (Rated Voltage)	DC 24 V	
04	电压范围 (Operating Voltage)	DC 20 - 26 V	
05	启动电压 (Starting Voltage)	DC 13.8 V	
06	频率 (Freq)		
07	额定电流 (Rated Current)	0.25 A	± 5%
08	额定功率 (Rated Power Consumption)	6 W	
09	转速 (Rotational Speed)	4800 R.P.M. ± 5%	
10	风量 (Airflow)	60 CFM (ft ³ /min)	
11	最大风压 (Max. Static Pressure)	10 mm-H ₂ O	
12	轴承类型 (Bearing type)	滚珠轴承	
13	噪音 (Noise Level)	33 dB(A)	
14	预计寿命 (Life Expectancy)	50000hrs at 25°C	
15	旋转方向 (Rotational Direction)		

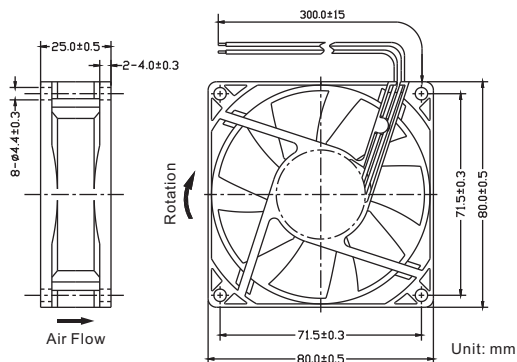

测试员：

日期： 2018.10.20