

Features :

- Constant current mode power supply
- Universal AC input / Full range
- Fully encapsulated with IP67 level
- Protections: Short circuit/Over current
- Small and compact size
- UL1310 Class 2 power unit, pass LPS
- 100% full load burn-in test
- Suitable for LED lighting and moving sign applications
- 2 years warranty

SPECIFICATION:

MODEL		LA35-350	LA35-700	LA35-1050	LA35-1400
OUTPUT	DC VOLTAGE	80V	48V	30V	24V
	DC VOLTAGE RANGE	30-80V	9-48V	9-30V	9-24V
	CURRENT RANGE	350mA ±3%	700mA ±3%	1050mA ±3%	1400mA ±3%
	RATED POWER	28W	34W	31.5W	34W
	RIPPLE & NOISE (max.)	300mVp-p	200mVp-p	200mVp-p	200mVp-p
	VOLTAGE TOLERANCE	±3.0%			
	LINE REGULATION	±1.0%			
	LOAD REGULATION	±2.0%			
	SETUP,RISE TIME	500ms,250ms/230VAC 500ms,250ms/115ac at full load			
	HOLD UP TIME (Typ.)	50ms/200VAC 24ms/100VAC at full load			
INPUT	VOLTAGE RANGE	100-240VAC			
	FREQUENCY RANGE	47~63Hz			
	EFFICIENCY(Typ.)	84% full load	84% full load	84% full load	84% full load
	AC CURRENT	0.75A/100VAC 0.35A/240VAC			
	INRUSH CURRENT (max.)	COLD STAT 70A/230VAC			
	LEAKAGE CURRENT	0.25mA/240VAC			
PROTECT ON	OVER CURRENT	Above 105% rated output power. Protection type: Hiccup mode, recovers automatically after fault condition is removed.			
	OVER TEMPERATURE	Tj 140℃ typically(U1) Detect on main control IC Protection type: Hiccup mode, recovers automatically after temperature goes down			
ENVIRONMENT	WORKING TEMP.	-10~50℃			
	WORKING HUMIDITY	20~90% RH non-condensing			
	STORAGE TEMP., HUMIDITY	-40~80℃, 10~95% RH			
	TEMP.COEFFICIENT	±0.03%/℃ (0~50℃)			
	VIBRATION	10~500Hz, 2G 10min./1cycle, period for 60min. each along X,Y, Z axes			
SAFETY & EMC	SAFETY STANDARDS	Design refer to UL1310 Class 2,TUV EN60950-1, EN61347-2-13, CAN/CSA C22.2 No. 223-M91, meet IP67			
	WITHSTAND VOLTAGE	I/P-O/P:3KVAC			
	ISOLATION RESISTANCE	I/P-O/P:>100M Ohms / 500VDC / 25~70% RH			
	EMI CONDUCTION & RADIATION	Compliance to EN55022 (CISPR22) Class B			
	HARMONIC CURRENT	Compliance to EN61000-3-2,-3			
EMS IMMUNITY	Compliance to EN61000-4-2,3,4,5,6,8,11; ENV50204, EN55024, light industry level, criteria A				
DIMENSION		148*32*28mm (L*W*H)			

Mechanical Specification

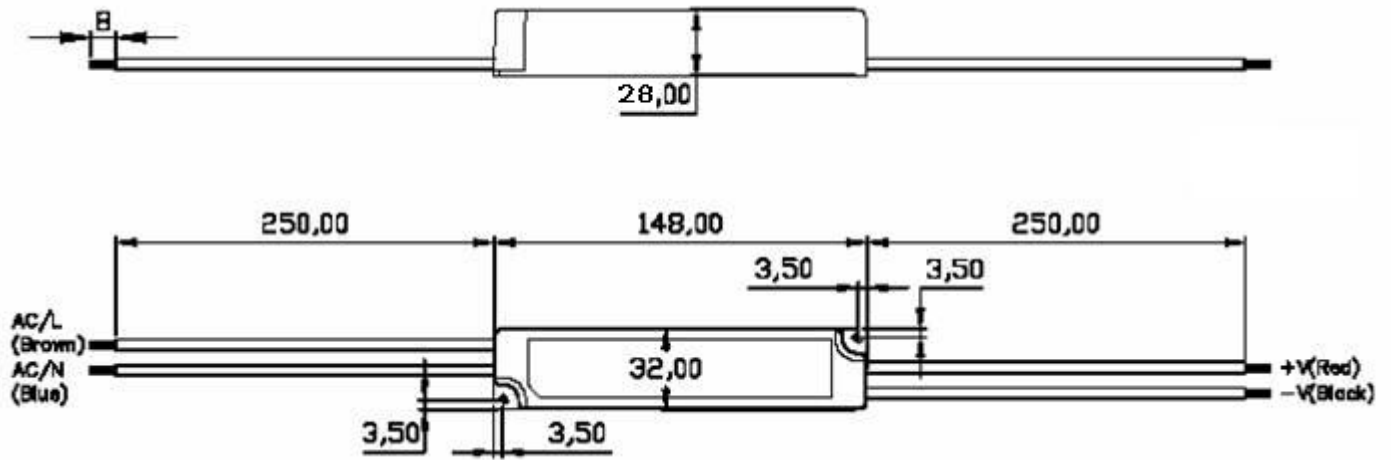

Block Diagram

