

**DESCRIPTION**

- Collector-Emitter Breakdown Voltage-  
:  $V_{(BR)CEO} = 60V(\text{Min})$
- High DC Current Gain-  
:  $h_{FE} = 20-100@I_C = 4A$
- Complement to Type MJE2955T

**APPLICATIONS**

- Designed for use in general-purpose amplifier and switching applications.

**ABSOLUTE MAXIMUM RATINGS( $T_a=25^\circ\text{C}$ )**

SYMBOL	PARAMETER	VALUE	UNIT
$V_{CBO}$	Collector-Base Voltage	70	V
$V_{CEO}$	Collector-Emitter Voltage	60	V
$V_{EBO}$	Emitter-Base Voltage	5	V
$I_C$	Collector Current-Continuous	10	A
$I_B$	Base Current-Continuous	6	A
$P_C$	Collector Power Dissipation @ $T_C=25^\circ\text{C}$	75	W
$T_J$	Junction Temperature	150	$^\circ\text{C}$
$T_{stg}$	Storage Temperature Range	-55~150	$^\circ\text{C}$

**THERMAL CHARACTERISTICS**

SYMBOL	PARAMETER	MAX	UNIT
$R_{th\ j-c}$	Thermal Resistance, Junction to Case	1.67	$^\circ\text{C/W}$

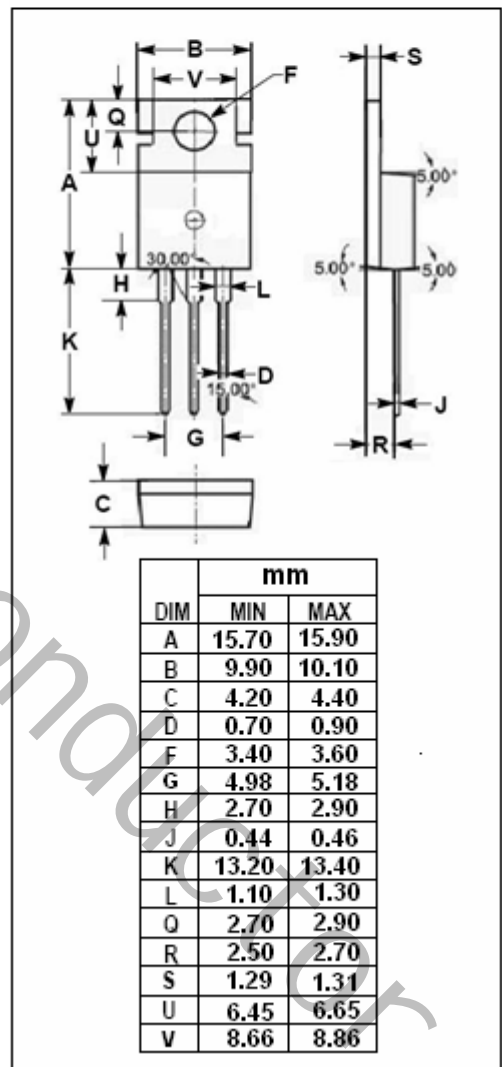
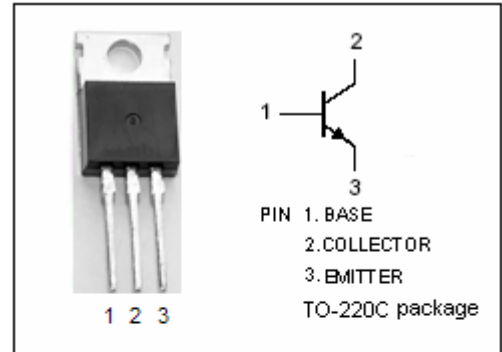

**ELECTRICAL CHARACTERISTICS**
 $T_C=25^{\circ}\text{C}$  unless otherwise specified

SYMBOL	PARAMETER	CONDITIONS	MIN	TYP.	MAX	UNIT
$V_{(BR)CEO}$	Collector-Emitter Breakdown Voltage	$I_C=200\text{mA}; I_B=0$	-60			V
$V_{CE(sat)-1}$	Collector-Emitter Saturation Voltage	$I_C=4\text{A}; I_B=0.4\text{A}$			1.1	V
$V_{CE(sat)-2}$	Collector-Emitter Saturation Voltage	$I_C=10\text{A}; I_B=3.3\text{A}$			8.0	V
$V_{BE(on)}$	Base-Emitter On Voltage	$I_C=4\text{A}; V_{CE}=4\text{V}$			1.8	V
$I_{CEX}$	Collector Cutoff Current	$V_{CE}=70\text{V}; V_{EB(off)}=-1.5\text{V}$ $V_{CE}=70\text{V}; V_{EB(off)}=-1.5\text{V}; T_C=150^{\circ}\text{C}$			1.0 5.0	mA
$I_{CEO}$	Collector Cutoff Current	$V_{CE}=30\text{V}; I_B=0$			0.7	mA
$I_{CBO}$	Collector Cutoff Current	$V_{CB}=70\text{V}; I_E=0$ $V_{CB}=70\text{V}; I_E=0; T_C=150^{\circ}\text{C}$			1.0 10	mA
$I_{EBO}$	Emitter Cutoff Current	$V_{EB}=5\text{V}; I_C=0$			5.0	mA
$h_{FE-1}$	DC Current Gain	$I_C=4\text{A}; V_{CE}=4\text{V}$	20		100	
$h_{FE-2}$	DC Current Gain	$I_C=10\text{A}; V_{CE}=4\text{V}$	5			
$f_T$	Current Gain-Bandwidth Product	$I_C=0.5\text{A}; V_{CE}=10\text{V}; f=500\text{kHz}$	2.0			MHz