

Specification

Main unit dimensions	L90°W145°H164mm ±5mm
Operating temperature	0 ~ 40°C / 32 ~ 104°F
Temperature range	200 ~ 480°C / 392 ~ 896°F
Display	LED Nixie
Tip to ground resistance	< 2 Ohms

I. Applications

1. Suitable for soldering and desoldering operations on a broad range of surface-mount, and through-hole components such as SOP, DIP, SOIC and more.
2. Effectively extract and filter the fume generated from soldering via the activated carbon filter. This helps cleanse the air in your work area efficiently.

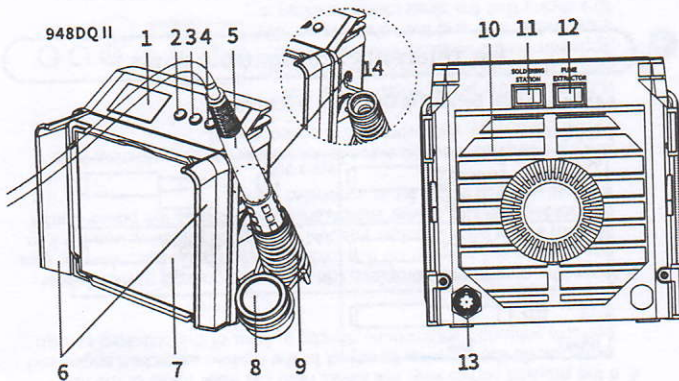

II. Reference Diagram

948DQ III

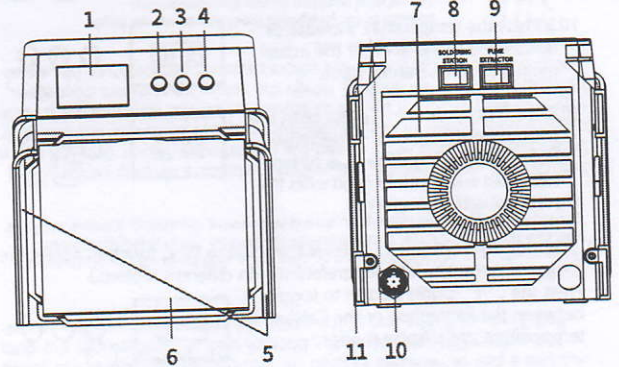

1. Temperature Display (Soldering Station)
2. Version A: Toggle Button (Fahrenheit / Celsius)
Version B: Function Button (220V-240V)
Note: Please refer to the rated voltage on the label to determine the version.
3. Temperature Decrease Button (Soldering Station)
4. Temperature Increase Button (Soldering Station)

5. Fender
6. Activated Carbon Filter
7. Exhaust
8. Power Switch (Soldering Station)
9. Power Switch (Fume Extractor)
10. Receptacle (Soldering Iron)
11. Stand

NOTE: The stand is sold separately, and it does not come with this product by default. If needed, contact our official store to purchase.

1. Temperature Display (Soldering Station)
2. Version A: Toggle Button (Fahrenheit / Celsius)
Version B: Function Button (220V-240V)
Note: Please refer to the rated voltage on the label to determine the version.
3. Temperature Decrease Button (Soldering Station)
4. Temperature Increase Button (Soldering Station)
5. Soldering Iron
6. Fender
7. Activated Carbon Filter
8. Clean
9. Soldering Iron Holder
10. Exhaust
11. Power Switch (Soldering Station)
12. Power Switch (Fume Extractor)
13. Receptacle (Soldering Iron)
14. Locking Screw (Soldering Iron Holder)

III. Operation

1. If the product comes with a solder wire dispenser, place the solder wire dispenser on the left side of the station and align the dispenser to the installation hole located on the left side of the station. Secure both the dispenser and the station, ensure the dispenser and the station are aligned parallel. Then, install the screw and tighten.
2. Push the fender from the top down into the installation slots (2-1).

3. Connect the soldering iron to the station, and place the soldering iron into the soldering iron holder.
4. Installing & Removing the activated carbon filter.

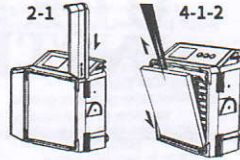

NOTE:
Dust and particles may scatter when replacing the activated carbon filter, please prepare sufficient desk protection.

- 4.1 Use a pair of tweezers to grab the top-middle position of the activated carbon filter, and pull the filter out gently (4-1-2).
- 4.2 Use a pair of tweezers to grab the top-middle position of the activated carbon filter and place the bottom-end of the filter into the slots first. Then, push the rest of the activated carbon filter into the slot (4-1-2).

NOTE:
To prevent loss of suction, please clean the residues off the activated carbon filter regularly. If the activated carbon filter is packed with excessive amount of residues, and it is beyond cleaning, please replace the activated carbon filter.

5. Turn ON the power switch. The soldering station's heating element will begin heating as per normal, and the operation indicator (located at the bottom-right corner of the temperature display) turns ON. The indicator stays ON when heating up, blinks rapidly when the temperature is stabilized, turns OFF when cooling. When the soldering station's operation indicator light blinks rapidly, the soldering iron's temperature has stabilized and the iron is ready for use.

 Indicator for program tracking temp. at high speed and making temp. compensation.

CAUTION: Upon the first use of the soldering iron, set the temperature to 250°C (482°F). When the iron is just hot enough to melt solder, coat the soldering iron tip with a layer of solder (the use of rosin core solder is recommended), then set the temperature to your desired temperature.

6. If the product comes with the stand, hold the front panel of the fume extractor, tilt the extractor to adjust to the desired extraction angle, and perform soldering applications directly in front of the activated carbon filter.

7. When the operation is complete, use a damped sponge or metal wool ball to clean the residues off the soldering iron tip. Tin the soldering iron tip with a new layer of solder again, then put the soldering iron back to the holder. Turn OFF power switch, and DISCONNECT the power cord if the station is not in use for an extended period.

8. Sleep Mode (This function extends the lifespan of the soldering iron, conserves energy, and protects the environment).

8.1 Turn ON the power switch, press and hold the button indicated in the picture for approximately 2 seconds. The display will show value "SLP" and then show value "ON" to indicate that the sleep mode function is currently turned ON. The duration of the countdown timer for sleep mode is approximately 10 minutes.



8.2 Press the soldering station's temperature decrease button to turn ON or OFF sleep mode.

8.3 Once done setting, stop operating for approximately 6 seconds. The system will automatically save the data and exit the setting interface - setting complete.

To wake the station:

- A. shake the iron a couple of times.
- B. Press any button on the panel.
- C. Turn OFF and then turn ON the power switch.

9. Auto Shutdown

When the soldering station enters sleep mode, its CPU will start counting down. If the soldering station is not wakened after 30 minutes, the soldering station will automatically shut off. Please restart the soldering station by turning the power switch OFF, then, turn the power switch back ON.

Note: The auto shutdown function activates ONLY when the sleep mode is turned ON.

10. Digital Temperature Calibration

Temperature discrepancies may occur due to the change in the environment's temperature or due to the replacement of the heating element and other components. You can correct the discrepancies with this function. The temperature calibration can help improve work efficiency and extend the lifespan of the soldering iron.

10.1 Once the temperature stabilizes, press and hold both the temperature increase and decrease buttons for approximately 2 seconds. The display will alternate with set temperature value, and the value "CAL".

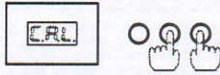

10.2 Press the temperature increase or decrease buttons to enter the actual measured temperature value.

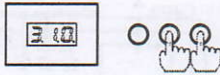

10.3 Once done entering, press both the temperature increase and decrease button to confirm entry. The system calibrates automatically and exits the setting interface.



11. **(Version A) Fahrenheit / Celsius Conversion** (This function allows the station to comply with user preferences in different regions.) Press the C°/F° Toggle Button to toggle between the Fahrenheit or the Celsius temperature unit display modes.



IV. Maintenance & Precautions

1. If a layer of oxidization forms on the surface of the soldering iron tip, a misconception can be created that the soldering tip cannot heat up properly to melt the solder and do the tinning. But the actual temperatures of both the heating element and soldering tip are high. In such an instance, please do not increase the temperature value confusedly but use a metal wool ball to remove the oxidization following the steps below:

- A. Set the temperature to 300°C (572°F).
- B. Once the temperature stabilizes, gently rub the soldering iron tip inside the metal wool ball.
- C. If the tip is too severely oxidized beyond cleaning, replace the tip with a new one.

2. DO NOT use metal files to remove the oxidization on the soldering iron tip. If the soldering iron tip deforms or rusts, replace the soldering iron tip with a new tip.

3. DO NOT apply excessive forces on the soldering tip when soldering. Doing so will not only damage the iron tip but also not improve the heat transfer.

4. When placing the soldering iron back in the holder to idle after a high-temperature operation, adjust the temperature to 250°C (482°F) or below for idling. Failure to do so and leaving the soldering iron tip to idle in a high-temperature setting will cause the accelerated aging of the heating element and shorten the lifespan of the heating element and soldering iron tip.

5. Clean the soldering iron tip after use, and tin the tip with a new layer of solder to prevent oxidization.

6. To avoid impacting the fume extraction performance negatively, DO NOT use the fume extractor in environments with strong airflows.

V. Troubleshooting

1. S-E - This is an indication that the station's sensor module is faulty. You need to replace the heating element (the heating element and the sensor modules). Or, the hot air gun is not connected (turn OFF the station, connect the hot air gun and turn ON the station).
2. When replacing the heating element, take note of the original connecting order and colors of the wires which MUST NOT be connected incorrectly.

For reference: compatible parts

948DQ II: 900M Series Tip Out Diam φ 6.5mm

948DQ III:

<p>902-B 0°C</p>	<p>902-3.2D 0°C</p>
<p>902-I -10°C/-18°F</p>	<p>902-3C 0°C</p>
<p>902-K 30°C/54°F</p>	

Tip style (specifications & sizes)

900M Series Tip Out Diam ϕ 6.5mm

948DQ11

<p>900M-T-0.8D 0°C ϕ 6.5mm 17mm</p>	<p>900M-T-LB -10°C/-18°F ϕ 6.5mm 25mm</p>	<p>900M-T-K 30°C/54°F 5.0mm 15mm</p>
<p>900M-T-1.2D 0°C ϕ 6.5mm 17mm</p>	<p>900M-T-0.5C 0°C ϕ 6.5mm 15mm</p>	<p>900M-T-R 0°C 2.2mm 5.0mm 17mm</p>
<p>900M-T-1.6D 0°C ϕ 6.5mm 17mm</p>	<p>900M-T-0.8C 0°C ϕ 6.5mm 17mm</p>	<p>900M-T-RT 0°C 2.8mm 17mm</p>
<p>900M-T-2.4D 0°C ϕ 6.5mm 17mm</p>	<p>900M-T-1C 0°C ϕ 6.5mm 15mm</p>	<p>900M-T-SI 0°C 2r 13mm</p>
<p>900M-T-3.2D 0°C ϕ 6.5mm 17mm</p>	<p>900M-T-1.5C 0°C ϕ 6.5mm 15mm</p>	<p>900M-T-I -10°C/-18°F 2r 17mm</p>
<p>900M-T-1.2LD -10°C/-18°F ϕ 6.5mm 25mm</p>	<p>900M-T-2C 0°C ϕ 6.5mm 17mm</p>	<p>900M-T-H -20°C/-36°F 1.5mm 7.5mm 25° 19mm</p>
<p>900M-T-SB 0°C 2r 14mm</p>	<p>900M-T-3C 0°C ϕ 6.5mm 17mm</p>	<p>900M-T-1.BH -10°C/-18°F 1.8mm 7.5mm 25° 14mm</p>
<p>900M-T-B 0°C 2r 17mm</p>	<p>900M-T-4C 0°C ϕ 6.5mm 17mm</p>	<p>900M-T-S4 0°C ϕ 6.5mm 15mm</p>