

### 1W SINGLE AUDIO POWER AMPLIFIER

KIA6278P/S/F are suitable for the audio power amplifier of portable radio cassette.

#### FEATURES

- Very few external parts counts  
(only three capacitor)
- Low Quiescent Current  
:  $I_{CCQ}=6.6\text{mA(Typ.)}$  ( $V_{CC}=6\text{V}$ )
- Wide operating supply voltage range.  
:  $V_{CC}=2\sim 10\text{V}$
- Output Power  
:  $P_{OUT}=720\text{mW(Typ.)}$  ( $V_{CC}=6\text{V}$ ,  $R_L=4\Omega$ ,  $\text{THD}=10\%$ )
- Voltage Gain :  $G_v=40\text{dB(Typ.)}$

#### MAXIMUM RATINGS ( $T_a=25^\circ\text{C}$ )

CHARACTERISTIC		SYMBOL	RATING	UNIT
Supply Voltage		$V_{CC}$	14	V
Power Dissipation (Peakage Limitation) (Note)	KIA6278P	$P_D$	900	mW
	KIA6278S		950	
	KIA6278F		400	
Operating Temperature		$T_{opr}$	$-25\sim 75$	$^\circ\text{C}$
Storage Temperature		$T_{stg}$	$-55\sim 150$	$^\circ\text{C}$

Note : Derated above  $T_a=25^\circ\text{C}$  in the proportion of  $7.2\text{mW}/^\circ\text{C}$ .

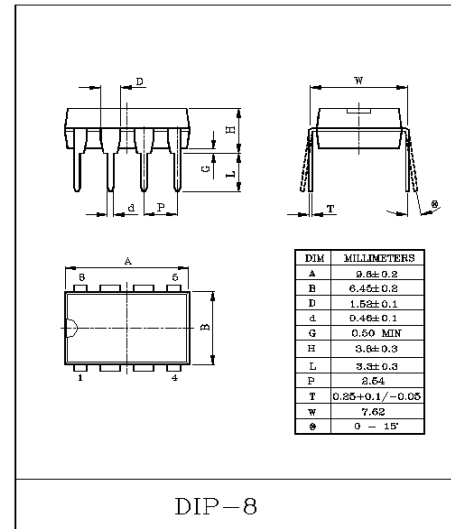

DIP-8

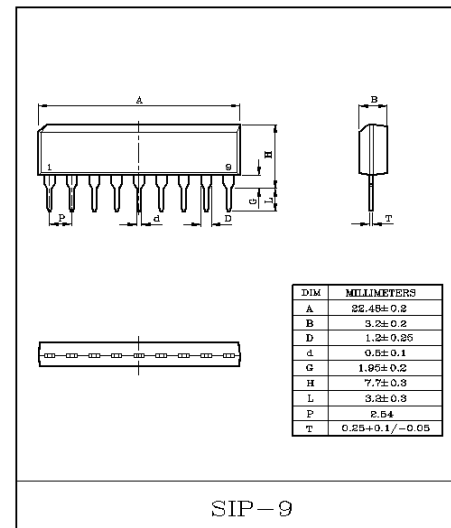

SIP-9

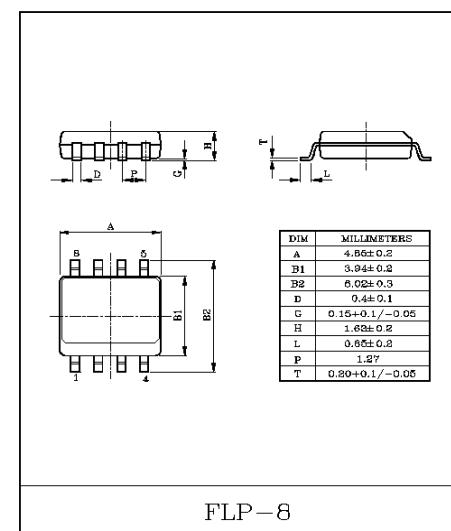

FLP-8

# KIA6278P/S/F

## ELECTRICAL CHARACTERISTICS

(Unless otherwise specified,  $V_{CC}=6V$ ,  $f=1kHz$ ,  $R_g=600\Omega$ ,  $R_L=4\Omega$ ,  $T_a=25^\circ C$ )

CHARACTERISTIC	SYMBOL	TEST CIRCUIT	TEST CONDITION	MIN.	TYP.	MAX.	UNIT
Quiescent Current	$I_{CCQ}$	-	$V_{CC}=3V, V_{IN}=0V$	-	5.5	-	mA
			$V_{CC}=6V, V_{IN}=0V$	-	6.6	15	
			$V_{CC}=9V, V_{IN}=0V$	-	7.5	18	
Output Power	$P_{OUT}$	-	$V_{CC}=3V, R_L=4\Omega, THD=10\%$	-	120	-	mW
			$V_{CC}=6V, R_L=4\Omega, THD=10\%$	500	720	-	
			$V_{CC}=6V, R_L=8\Omega, THD=10\%$	300	450	-	
			$V_{CC}=9V, R_L=8\Omega, THD=10\%$	800	1100	-	
			$V_{CC}=9V, R_L=16\Omega, THD=10\%$	450	610	-	
Total Harmonic Distortion	THD	-	$P_{OUT}=100mW$	-	0.3	1.0	%
Voltage Gain	$G_V$	-	$V_{IN}=0.5mV_{rms}$	37	40	43	dB
Output Noise Voltage	$V_{NO}$	-	$R_g=10k\Omega, BW=20Hz\sim 20kHz$	-	0.2	0.5	$mV_{rms}$
Ripple Rejection Ratio	R.R.	-	$f_{RIP}=100Hz, V_{RIP}=0.3V_{rms}$ Without $C_{RIP}$	-	25	-	dB
Input Resistance	$R_{IN}$	-		-	27	-	$k\Omega$

## TYPICAL VOLTAGE OF EACH TERMINAL (KIA6278S)

( $V_{CC}=6V, T_a=25^\circ C$ , by test circuit)

(unit:V)

TERMINAL NO.	1	2	3	4	5	6	7	8	9
DC Voltage	0	2.40	0.62	0.64	0	0	2.61	NC	6.0

# KIA6278P/S/F

## TEST CIRCUIT & BLOCK DIAGRAM

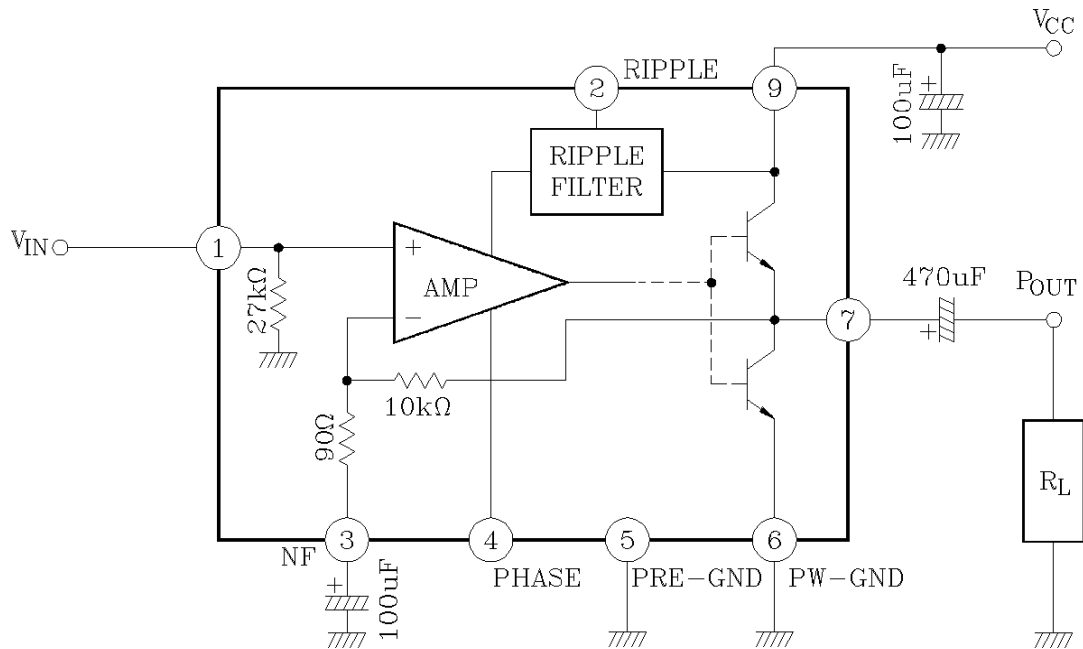

Note : The  $V_{CC}$  of KIA6278S is Pin ⑨  
The  $V_{CC}$  of KIA6278P/F are Pin ⑧

# KIA6278P/S/F

## PRECAUTION FOR USE AND APPLICATION

### 1) Input Stage

The input stage of power amplifier (Equivalent circuit) is comprised of a PNP differential pair (Q2 and Q3) preceded by a PNP emitter follower (Q1) which allows DC referencing of the source signal to ground.

This eliminates the need for an input coupling capacitor. However, in case the brush noise of volume becomes a problem, provide serially a coupling capacitor to the input side.

### 2) Adjustment of Voltage Gain

The voltage gain is fixed at  $G_V=40\text{dB}$  by the resistors (R4 and R5) in IC, however, its reduction is possible through adding  $R_f$  as shown in Fig 2. In this case, the voltage gain is obtained by the following Equation.

$$G_V = 20 \log \frac{R_5 + R_4 + R_f}{R_4 + R_f}$$

It is recommended to use this IC with the voltage gain of  $G_V=28\text{dB}$  or over.

### 3) Ripple Rejection Ratio

Adding  $C_{RIP}$  to terminal 2 as shown Fig 3, the Ripple Rejection ratio is improved from  $-25\text{dB Typ.}$  to  $-45\text{dB Typ.}$  (in case of  $C_{RIP}=100\mu\text{F}$ ). Refer to R.R. vs.  $f$  characteristics.

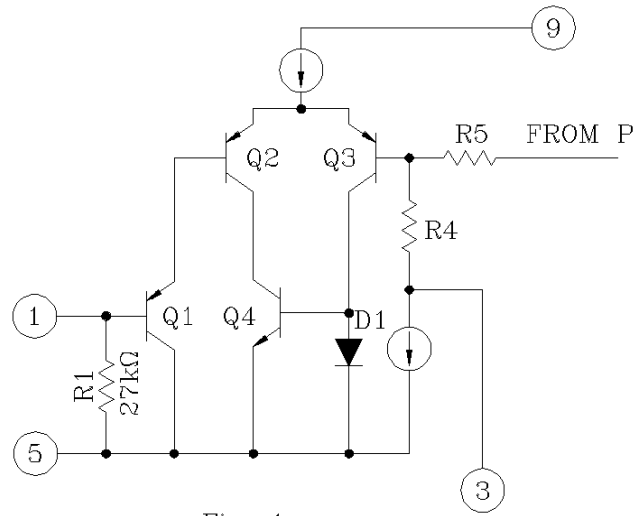

Fig. 1

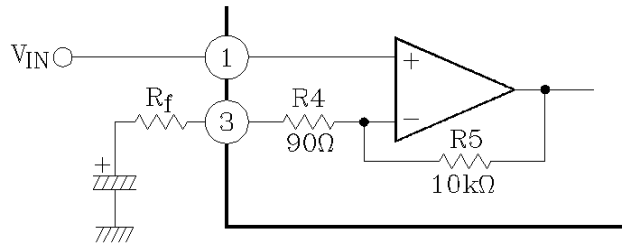

Fig. 2

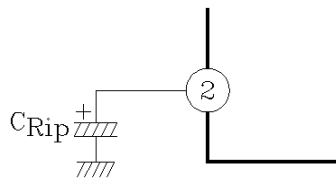

Fig. 3

# KIA6278P/S/F

