

85°C Miniature Standard Capacitors, 9-25mm Height Low Profile Series.

Miniaturized low profile.

Height 9mm-25mm max.

Safety vent construction design.

RoHS Compliant



Outline Drawing

Unit: mm

Photo

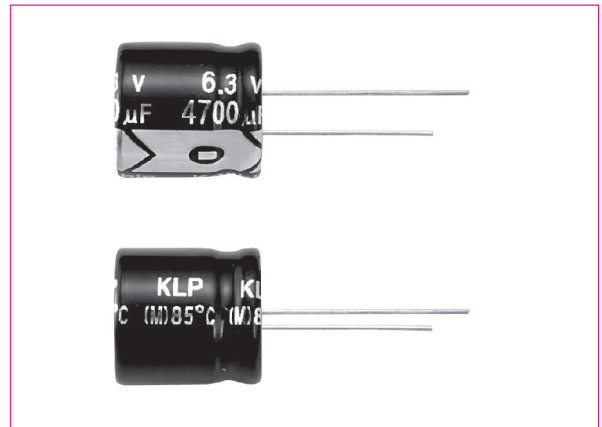
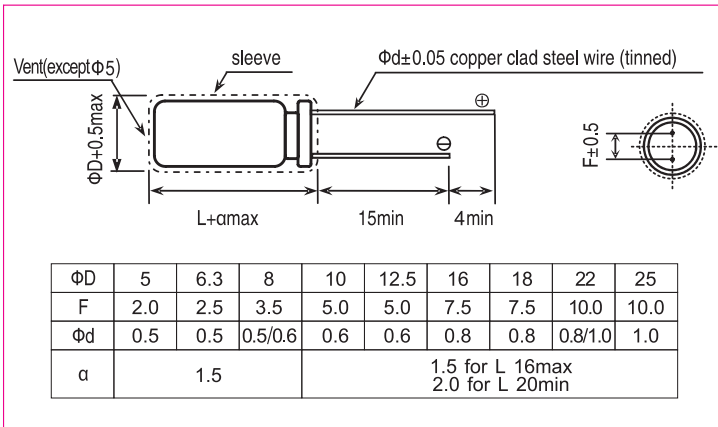

Marking color: white print on black sleeve

Specifications

No.	Item	Performance
1	Temperature range (°C)	-40 to +85 (6.3V~100V) -25 to +85 (160V~450V)
2	Leakage current (μA)	Less than 0.01CV or 3 whichever is larger (after one minutes) Less than 0.03CV or 3 whichever is larger (after one minutes) C: Rated Capacitance (μF). V: Rated voltage (V) 20°C
3	Capacitance tolerance (%)	20 (20°C, 120Hz)
4	Tangent of the loss angle (Tan δ)	Rated voltage (V) 6.3 10 16 25 35 50 63 100 160-250 350-450 20°C
		Tan δ (max) 0.22 0.19 0.16 0.14 0.12 0.10 0.09 0.08 0.15 0.15 120Hz
0.02 is added to each 1000uF increase over 1000uF.		
5	Low temperature characteristics	Rated voltage (V) 6.3 10 16 25 35 50 63 100 160-250 350-450
		Impedance ratio (max) Z(-25°C)/Z(+20°C) 4 3 2 2 2 2 2 2 4 6 120Hz
		Z(-40°C)/Z(+20°C) 8 6 4 4 3 3 3 3 15 10
6	Endurance (85°C) (Applied ripple current)	Test time 2000hours
		Leakage current The initial specified value or less
		Percentage of capacitance change Within 20% of initial value
		Tangent of the loss angle 200% or less of the initial specified value
7	Shelf life (85°C)	Test time 1000hours
		Leakage current The initial specified value or less
		Percentage of capacitance change Within 20% of initial value
		Tangent of the loss angle 200% or less of the initial specified value
8	Applicable standards	JIS-C-5102 and JIS-C-5141

KLP Miniature Aluminum Electrolytic Capacitors

Dimension: Φ DXL(mm)

Ripple Current: mA/rms at 120Hz,85°C

DIMENSION & PERMISSIBLE RIPPLE CURRENT

V,DC Contents μ F	6.3V				10V				16V				25V			
	Φ D×L	mA	* Φ D×L	mA	Φ D×L	mA	* Φ D×L	mA	Φ D×L	mA	* Φ D×L	mA	Φ D×L	mA	* Φ D×L	mA
4.7																
10																
22																
33																
47													5X9	105		
68									5X9	120			6.3X9	130		
100	5X9	128			5X9	134			6.3X9	160			6.3X9	175		
150	5X9	150			6.3X9	180			6.3X9	260			8X9	280		
220	6.3X9	180			6.3X9	210			8X9	290			8X9	310		
330	6.3X9	247			8X9	300			8X9	340	10X9	355	10X9	400		
470	8X9	360			8X9	360			10X9	410			10X12.5	525		
680	10X9	420			10X9	540			10X12.5	560			10X16	700	12.5X13	730
1000	10X9	530			10X12.5	625			12.5X13	750			12.5X16	1050		
2200	12.5X16	1050			12.5X16	1080			16X16	1150			16X21	1350	18X16	1300
3300	16X16	1200			16X16	1350			16X16	1500	18X16	1460	18X21	1600		
4700	16X16	1500			16X21	1550			18X21	1650			18X25	2100		
6800	16X21	1550	18X16	1600	18X21	1850			18X25	2120						
10000	18X21	2000			18X25	2300										
22000																

V,DC Contents μ F	35V				50V				63V				100V			
	Φ D×L	mA	* Φ D×L	mA	Φ D×L	mA	* Φ D×L	mA	Φ D×L	mA	* Φ D×L	mA	Φ D×L	mA	* Φ D×L	mA
2.2					5X9	23			5X9	26			5X9	27		
3.3					5X9	30			5X9	31			5X9	33		
4.7					5X9	35			5X9	36			6.3X9	41		
6.8					5X9	50			5X9	54			6.3X9	59		
10					5X9	64			6.3X9	68			8X9	78		
22					5X9	86			6.3X9	102			8X9	107		
33	5X9	95			6.3X9	115			8X9	135			10X9	155		
47	6.3X9	120			6.3X9	135			10X9	170			10X16	220		
68	6.3X9	140			8X9	155			10X9	200			10X16	261	12.5X13	270
100	8X9	220			10X9	230			10X16	340			12.5X13	410		
150	8X9	300			10X9	320			12.5X13	384			16X16	579		
220	10X9	335			10X16	380	12.5X13	400	12.5X13	490			16X21	668		
330	10X12.5	475			12.5X13	530	12.5X16	550	16X16	610			16X25	864		
470	12.5X13	590	12.5X16	650	12.5X16	720	16X16	750	16X16	840			18X25	1361		
680	12.5X16	750			16X16	805			16X21	950						
1000	16X16	1230			16X21	1450			18X25	1600						
2200	18X21	1600			18X25	1650										
3300	18X25	1750														
4700																

Dimension: Φ DXL(mm)

Ripple Current: mA/rms at 120Hz,85°C

DIMENSION & PERMISSIBLE RIPPLE CURRENT

V.DC Contents μ F	160V				200V				250V			
	Φ D×L	mA	* Φ D×L	mA	Φ D×L	mA	* Φ D×L	mA	Φ D×L	mA	* Φ D×L	mA
0.47												
1												
2.2												
3.3												
4.7	8X9	50			8X9	55			8X9	60	10X9	52
6.8	8X9	75			8X9	78			10X9	82		
10	10X9	87			10X9	92			10X9	98	10X16	120
22	10X16	135			12.5X16	150			12.5X16	165	16X16	210
33	12.5X16	175			12.5X16	190	16X16	200	16X16	230	18X16	260
47	12.5X16	285	16X16	325	16X16	320			16X21	340	18X16	380
68	16X16	340			16X16	360	18X16	390	16X21	420		
100	16X21	515			16X21	575			18X21	610		
150	18X21	620			18X25	645			18X25	685		
220	18X25	840										
330												
470												

V.DC Contents μ F	350V				400V				450V			
	Φ D×L	mA	* Φ D×L	mA	Φ D×L	mA	* Φ D×L	mA	Φ D×L	mA	* Φ D×L	mA
1.5									8X9	30		
2.2					8X9	38			10X9	46		
3.3	8X9	45			10X9	50			10X9	55		
4.7	10X9	78			10X9	90			10X12.5	105		
6.8	10X16	105			12.5X16	125			12.5X16	135		
10	12.5X16	145			12.5X16	160	16X16	190	16X16	200		
22	16X16	190			16X21	230	18X16	225	16X21	250		
33	16X21	270	18X16	335	18X21	300			18X21	320		
47	18X21	360			18X21	385			18X25	410		
68	18X25	510			18X25	540						
100												
120												
150												
180												

Coefficient of Frequency for Ripple Current

Rated voltage (V)	Frequency (Hz)	50 • 60	120	1K	10K	100K
	CV ($\mu F \times V$)					
6.3 to 16	All CV value	0.80	1.00	1.30	1.50	1.50
25 to 35	≤ 1000	0.80	1.00	1.30	1.50	1.50
	> 1000	0.80	1.00	1.20	1.30	1.30
50 to 100	≤ 1000	0.80	1.00	1.20	1.30	1.30
	> 1000	0.80	1.00	1.10	1.20	1.20
160 to 450	All CV value	0.80	1.00	1.10	1.20	1.20

Coefficient of Temperature for Ripple Current

Temperature (°C)	70 or less	85
Coefficient	1.35	1.00