

LP377THR1-40G

Features

Low Profile
 4 Pin Plastic Package
 Water Clear Lens
 High Flux Output
 High Current Operation

Applications

Automotive Interior Exterior Lighting
 Rail Signals
 Traffic Control Devices
 Channel Letters
 Strip Lighting
 Architectural Lighting

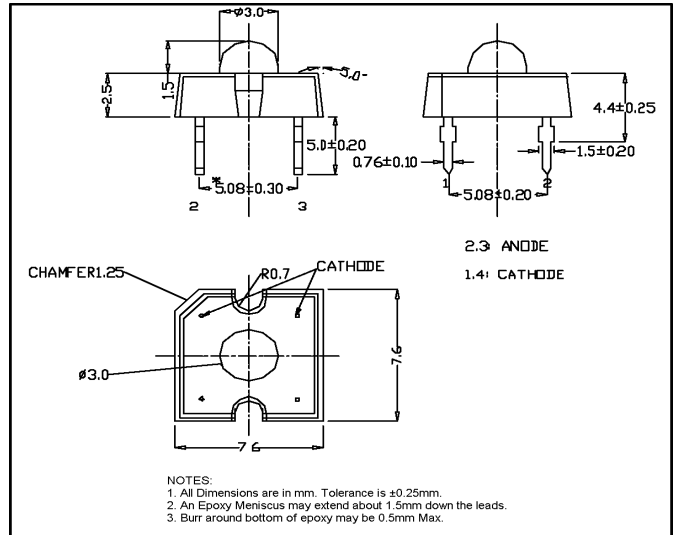

Maximum Ratings (Ta=25°C)

Characteristic	Symbol	Max.	Unit
Forward Current	I_F	70	mA
Reverse Voltage	V_R	5.00	V
Power Dissipation	P_D	150.00	mW
Operating Temperature	T_{opr}	-40 ~ +100	°C
Storage Temperature	T_{stg}	-40 ~ +100	°C
Soldering Temperature	T_{sol}	260	°C
Soldering Time	-	for 5 sec. max	-

Opto-Electrical Characteristics (Ta=25°C)

Characteristic	Symbol	Test Condition	Min	Typ	Max	Unit
Forward Voltage	V_F	$I_F=70\text{mA}$	2.20	2.60	3.00	V
Reverse Current	I_R	$V_R=5\text{V}$	-	-	100	μA
Luminous Flux	Φ	$I_F=70\text{mA}$	3000.00	4000.00	-	mlm
Viewing Angle	$2\theta^{1/2}$	-	-	40°	-	deg.
Peak Wavelength	λ_p	$I_F=70\text{mA}$	-	639	-	nm
Dominant Wavelength	λ_d	$I_F=70\text{mA}$	-	628	-	nm
Spectral Line Half Width	$\Delta\lambda$	$I_F=70\text{mA}$	-	23	-	nm

LP377THR1-40G Graphs

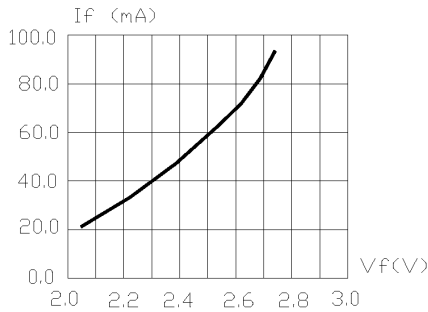

FIG.1 FORWARD CURRENT VS. FORWARD VOLTAGE.

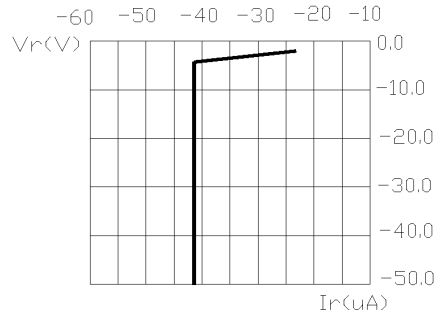

FIG.2 REVERSE CURRENT VS. REVERSE VOLTAGE.

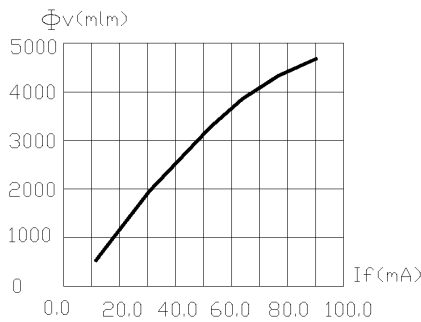

FIG.3 RELATIVE FLUX VS. FORWARD CURRENT.

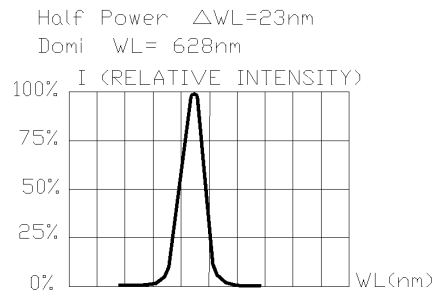

FIG.4 RELATIVE INTENSITY VS. WAVE LENGTH.

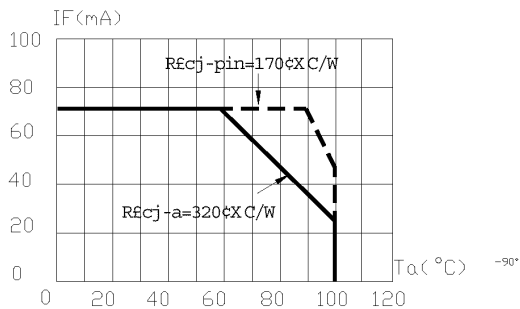

FIG.5 MAXIMUM FORWARD DC CURRENT VS TEMPERATURE. DERATING BASED ON $T_{jmax}=120^{\circ}C$

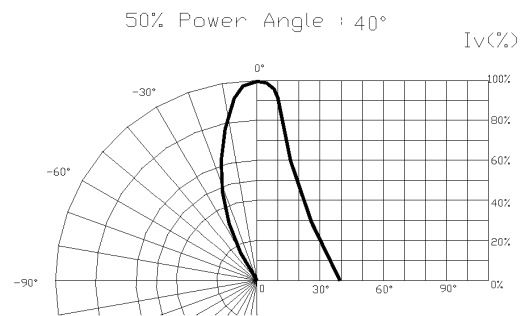

FIG.6 SPATIAL DISTRIBUTION.

1. Cathode PAD Area ($0.18 \times 0.18 \times 2 \text{inch}^2$)
2. Height above nominal seating plane in inches (0.3inch)