

REVISIONS			
REV	DESCRIPTION	DATE	BY

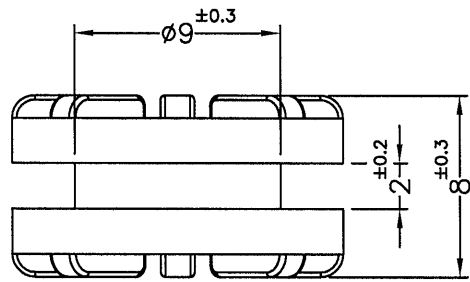

PART NO.	COLOR	HARDNESS
TGM-40G(B)	BLACK	45° ± 10°
TGM-40H(B)		55° ± 10°
TGM-40(70)W	WHITE	70° ± 10°

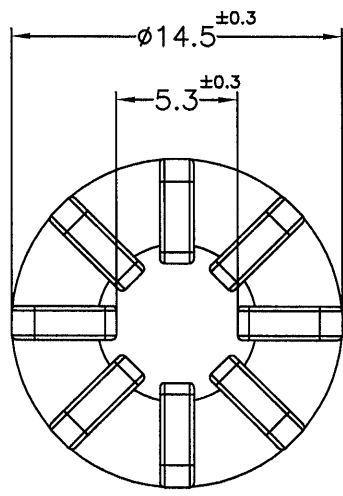

NOTE:MADE OF EQUIVALENT MATERIAL.  
可使用同等材質.

**K**  
 康揚企業股份有限公司  
 KANG YANG HARDWARE ENTERPRISE CO., LTD.  
 康揚塑膠(東莞)有限公司  
 KANG YANG PLASTIC(DONG GUAN )CO.,LTD.  
 ISO 9001  
 ISO 14001  
 QC 080000  
 康哲電腦配件(吳江)有限公司  
 KANG CHE COMPUTER COMPONENTS(WUJIANG) CO.,LTD.

TITLE	ANTI-VIBRATE GROMMET	SPEC. DWG.
MATERIAL	TPE	DATE 2009.09.17
HARDNESS	SEE ABOVE	DRAWN JIM
COLOR	SEE ABOVE	CHECK 
UNLESS OTHERWISE SPECIFIED TOLERANCE	SEE ABOVE	APPROVED <i>Kang</i>

PART NUMBER	SEE ABOVE	DRAWING NUMBER	TGM-40
SIZE	A4	SCALE	3:1
UNIT	mm	REV	C