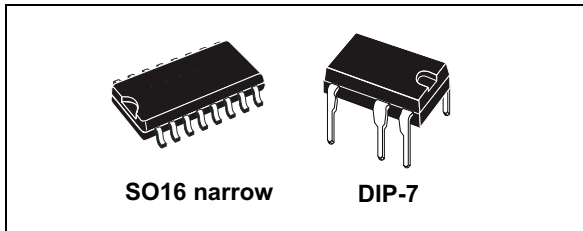


## Peak power high-voltage converter - VIPer Plus

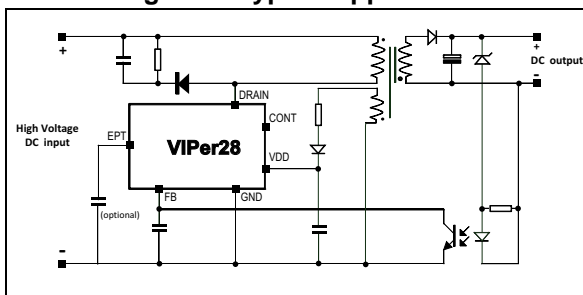
Datasheet - production data



SO16 narrow

DIP-7

Figure 1. Typical application



### Features

- 800 V avalanche-rugged power MOSFET allowing achieving ultra wide-range input  $V_{ac}$
- Embedded HV startup and sense FET
- PWM current-mode controller
- OCP with selectable threshold ( $I_{Dlim}$ ) and 2<sup>nd</sup> OCP with higher value ( $I_{DMAX}$ ) to protect the IC from transformer saturation or short-circuit of the secondary diode
- 30 mW no-load consumption at 230  $V_{ac}$
- Two operating frequencies:
  - 60 kHz (L type) or 115 kHz (H type)
- Jittered frequency reduces the EMI
- Extra power timer (EPT) blanks the overload current for few seconds
- Output overvoltage protection with tight tolerance and digital noise filter
- Soft-start reduces the stress during startup and increases IC lifetime
- Automatic restart after a fault condition

- Thermal shutdown increases system reliability and IC lifetime

### Applications

- Auxiliary power supply for consumer and home equipment
- Power supply for energy meters and data concentrators
- AC-DC adapters

### Description

The device is a high-voltage converter that smartly integrates an 800 V rugged power MOSFET with PWM current-mode control. This IC is capable of meeting more stringent energy-saving standards as it has very low consumption and operates in burst mode under light load. The device features an adjustable extra power timer (EPT) that enables the IC to sustain overload conditions for a few seconds. The integrated HV startup, sense FET and oscillator with jitter allow the advantage of using minimal components in the application. The device features high-level protections like dual-level OCP, output overvoltage, short-circuit, and thermal shutdown with hysteresis. After the removal of a fault condition, the IC is automatically restarted.

Table 1. Device summary

Order codes	Package	Packaging
VIPER28LN / VIPER28HN	DIP-7	Tube
VIPER28HD / VIPER28LD	SO16 narrow	
VIPER28HDTR / VIPER28LDTR		

# Contents

<b>1</b>	<b>Block diagram</b> .....	<b>5</b>
<b>2</b>	<b>Typical power</b> .....	<b>5</b>
<b>3</b>	<b>Pin settings</b> .....	<b>6</b>
<b>4</b>	<b>Electrical ratings</b> .....	<b>7</b>
	4.1 Electrical characteristics .....	8
<b>5</b>	<b>Typical electrical characteristics</b> .....	<b>11</b>
<b>6</b>	<b>Typical circuit</b> .....	<b>13</b>
<b>7</b>	<b>Operation</b> .....	<b>14</b>
	7.1 Power section and gate driver .....	14
	7.2 High-voltage startup generator .....	14
	7.3 Power-up and soft startup .....	14
	7.4 Power-down .....	17
	7.5 Auto-restart .....	17
	7.6 Oscillator .....	18
	7.7 Current mode conversion with adjustable current limit setpoint .....	18
	7.8 Overvoltage protection (OVP) .....	18
	7.9 About CONT pin .....	20
	7.10 Feedback and overload protection (OLP) .....	20
	7.11 Burst-mode operation at no load or very light load .....	23
	7.12 Extra power timer (EPT) .....	24
	7.13 2nd level overcurrent protection and hiccup mode .....	25
<b>8</b>	<b>Package mechanical data</b> .....	<b>26</b>
	8.1 DIP-7 package information .....	26
	8.2 SO16 Narrow package information .....	28
<b>9</b>	<b>Revision history</b> .....	<b>30</b>

## List of tables

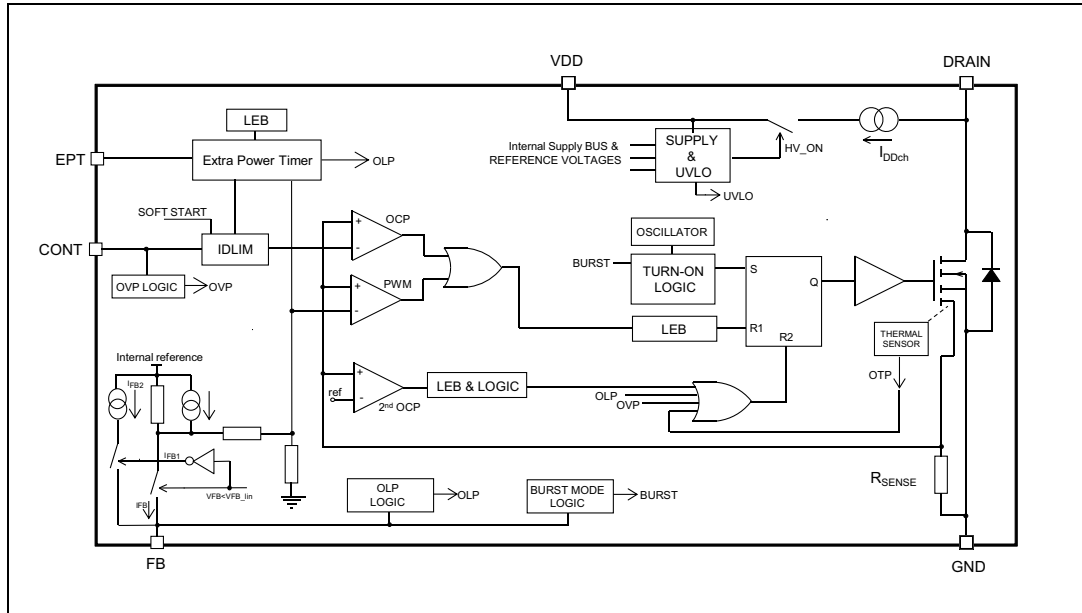
Table 1.	Device summary . . . . .	1
Table 2.	Typical power . . . . .	5
Table 3.	Pin description . . . . .	6
Table 4.	Absolute maximum ratings . . . . .	7
Table 5.	Thermal ratings . . . . .	7
Table 6.	Avalanche ratings . . . . .	7
Table 7.	Power section . . . . .	8
Table 8.	Supply section . . . . .	8
Table 9.	Controller section . . . . .	9
Table 10.	CONT pin configurations . . . . .	20
Table 11.	DIP-7 mechanical data . . . . .	27
Table 12.	SO16 Narrow mechanical data . . . . .	29
Table 13.	Document revision history . . . . .	30

## List of figures

Figure 1.	Typical application	1
Figure 2.	Block diagram	5
Figure 3.	Connection diagram (top view)	6
Figure 4.	Minimum turn-on time test circuit	10
Figure 5.	OVP threshold test circuit	10
Figure 6.	$I_{Dlim}$ vs. $T_J$	11
Figure 7.	$F_{OSC}$ vs. $T_J$	11
Figure 8.	$V_{DRAIN\_START}$ vs. $T_J$	11
Figure 9.	$I_{DD0}$ vs. $T_J$	11
Figure 10.	$I_{DD1}$ vs. $T_J$	11
Figure 11.	Main FET $R_{DSON}$ vs. $T_J$	11
Figure 12.	Main FET $V_{BVDSS}$ vs. $T_J$	12
Figure 13.	$I_{Dlim}$ vs. $R_{LIM}$	12
Figure 14.	Thermal shutdown	12
Figure 15.	Basic flyback application	13
Figure 16.	Full-featured flyback application	13
Figure 17.	$I_{DD}$ current during startup and burst mode	15
Figure 18.	Timing diagram: normal power-up and power-down sequences	16
Figure 19.	Soft-start: timing diagram	16
Figure 20.	Timing diagram: behavior after short-circuit	17
Figure 21.	OVP timing diagram	19
Figure 22.	CONT pin configuration	20
Figure 23.	FB pin configuration (option 1)	22
Figure 24.	FB pin configuration (option 2)	22
Figure 25.	Burst mode timing diagram, light load	23
Figure 26.	EPT timing diagram	24
Figure 27.	DIP-7 package outline	26
Figure 28.	SO16 narrow package outline	28

# 1 Block diagram

Figure 2. Block diagram



# 2 Typical power

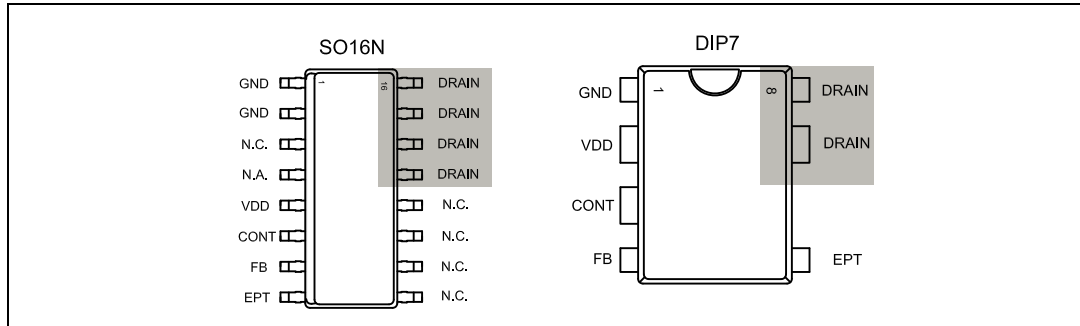
Table 2. Typical power

Nominal power	230 V <sub>AC</sub>		85-265 V <sub>AC</sub>	
	Adapter <sup>(1)</sup>	Open frame <sup>(2)</sup>	Adapter <sup>(1)</sup>	Open frame <sup>(2)</sup>
VIPER28xD/xN	13 W	16 W	10 W	12 W
	22 W (peak) <sup>(3)</sup>	26 W (peak) <sup>(3)</sup>	17 W (peak) <sup>(3)</sup>	20 W (peak) <sup>(3)</sup>

1. Typical continuous power in non-ventilated enclosed adapter measured at 50 °C ambient.
2. Maximum practical continuous power in an open frame design at 50 °C ambient, with adequate heat sinking.
3. Maximum practical peak power at 50 °C ambient, with adequate heat sinking for 2 sec (max).

### 3 Pin settings

Figure 3. Connection diagram (top view)



Note: The copper area for heat dissipation has to be designed under the DRAIN pins.

Table 3. Pin description

SO16N	Name	Function
1, 2	GND	This pin represents the device ground and the source of the power section.
3	N.C.	Not connected.
4	N.A.	Not available for user. This pin is mechanically connected to the controller die pad of the frame. In order to improve the noise immunity, is highly recommended connect it to GND (pin 1-2).
5	VDD	Supply voltage of the control section. This pin also provides the charging current of the external capacitor during startup.
6	CONT	Control pin. The following functions can be selected: 1. current limit setpoint adjustment. The default value (set internally) of the cycle-by-cycle current limit can be reduced by connecting an external resistor to ground. 2. output voltage monitoring. A voltage exceeding the $V_{OVP}$ threshold (see <a href="#">Table 9: Controller section on page 9</a> ) shuts the IC down, reducing device consumption. This function is strobed and digitally filtered for high noise immunity.
7	FB	Control input for duty cycle control. The internal current generator provides bias current for loop regulation. A voltage below the threshold $V_{FBbm}$ activates burst-mode operation. A level close to the threshold $V_{FBlin}$ means that we are approaching the cycle-by-cycle overcurrent setpoint.
8	EPT	This pin allows the connection of an external capacitor for extra power management. If the function is not used, the pin has to be connected to GND.
9...12	N.C.	Not connected.
13...16	DRAIN	High-voltage drain pin. The built-in high-voltage switched startup bias current is drawn from this pin too. These pins are connected to the metal frame to facilitate heat dissipation.

## 4 Electrical ratings

**Table 4. Absolute maximum ratings**

Symbol	Parameter	Value		Unit
		Min	Max	
$V_{DRAIN}$	Drain-to-source (ground) voltage		800	V
$I_{DRAIN}$	Pulse drain current (limited by $T_J = 150\text{ °C}$ )		3	A
$V_{CONT}$	Control input pin voltage	-0.3	6	V
$V_{FB}$	Feedback voltage	-0.3	5.5	V
$V_{EPT}$	EPT input pin voltage	-0.3	5	V
$V_{DD}$	Supply voltage ( $I_{DD} = 25\text{ mA}$ )	-0.3	Self limited	V
$I_{DD}$	Input current		25	mA
$P_{TOT}$	Power dissipation at $T_A < 40\text{ °C}$ (DIP-7)		1	W
	Power dissipation at $T_A < 60\text{ °C}$ (SO16N)		1.5	
$T_J$	Operating junction temperature range	-40	150	°C
$T_{STG}$	Storage temperature	-55	150	°C
$HBM_{(ESD)}$	Human body model		2	kV
$ESD_{(CDM)}$	Charge device mode		1.5	

**Table 5. Thermal ratings**

Symbol	Parameter	Max value		Unit
		SO16N	DIP7	
$R_{thJP}$	Thermal resistance junction pin (dissipated power = 1 W)	35	35	°C/W
$R_{thJA}$	Thermal resistance junction ambient (dissipated power = 1 W)	105	110	°C/W
$R_{thJA}$	Thermal resistance junction ambient <sup>(1)</sup> (dissipated power = 1 W)	80	90	°C/W

1. When mounted on a standard single side FR4 board with 100 mm<sup>2</sup> (0.155 sq inch) of Cu (35 µm thick)

**Table 6. Avalanche ratings**

Symbol	Parameter	Test condition	Value	Unit
$I_{AS}$	Avalanche current	Repetitive or non repetitive (pulse width limited by $T_{Jmax}$ )	1	A
$E_{AS}$	Single pulse avalanche energy <sup>(1)</sup>	$I_D = I_{AS}$ , $V_{DS}=100\text{ V}$ starting $T_J = 25\text{ °C}$	3	mJ

1. This parameter is derived from characterization data.

### 4.1 Electrical characteristics

$T_J = -25$  to  $125$  °C,  $V_{DD} = 14$  V; unless otherwise specified (adjust  $V_{DD}$  above  $V_{DDon}$  startup threshold before setting to 14 V).

**Table 7. Power section**

Symbol	Parameter	Test condition	Min	Typ	Max	Unit
$V_{BVDSS}$	Breakdown voltage	$I_{DRAIN} = 1$ mA, $V_{FB} = GND$ , $T_J = 25$ °C	800			V
$I_{OFF}$	OFF-state drain current	$V_{DRAIN} = \text{max rating}$ , $V_{FB} = GND$ , $T_J = 25$ °C			60	µA
$R_{DS(on)}$	Drain-source on-state resistance	$I_{DRAIN} = 0.4$ A, $V_{FB} = 3$ V, $V_{EPT} = GND$ , $T_J = 25$ °C			7	Ω
		$I_{DRAIN} = 0.4$ A, $V_{FB} = 3$ V, $V_{EPT} = GND$ , $T_J = 125$ °C			14	Ω
$C_{OSS}$	Effective (energy related) output capacitance	$V_{DRAIN} = 0$ to 640 V, $T_J = 25$ °C		40		pF

**Table 8. Supply section**

Symbol	Parameter	Test condition	Min	Typ	Max	Unit
<b>Voltage</b>						
$V_{DRAIN\_START}$	Drain-source start voltage		60	80	100	V
$I_{DDch1}$	Startup charging current	$V_{DRAIN} = 120$ V, $V_{EPT} = GND$ , $V_{FB} = GND$ , $V_{DD} = 4$ V	-2	-3	-4	mA
$I_{DDch2}$	Restart charging current (after fault)	$V_{DRAIN} = 120$ V, $V_{EPT} = GND$ , $V_{FB} = GND$ , $V_{DD} = 5$ V	-0.4	-0.6	-0.8	mA
$V_{DD}$	Operating voltage range	After turn-on	8.5		23.5	V
$V_{DDclamp}$	$V_{DD}$ clamp voltage	$I_{DD} = 20$ mA	23.5			V
$V_{DDon}$	$V_{DD}$ startup threshold	$V_{DRAIN} = 120$ V, $V_{EPT} = GND$ , $V_{FB} = GND$	13	14	15	V
$V_{DDoff}$	$V_{DD}$ undervoltage shutdown threshold		7.5	8	8.5	V
$V_{DD(RESTART)}$	$V_{DD}$ restart voltage threshold	$V_{DRAIN} = 120$ V, $V_{EPT} = GND$ , $V_{FB} = GND$	4	4.5	5	V
<b>Current</b>						
$I_{DD0}$	Operating supply current, not switching	$V_{FB} = GND$ , $F_{OSC} = 0$ kHz $V_{EPT} = GND$ , $V_{DD} = 10$ V			0.9	mA
$I_{DD1}$	Operating supply current, switching	$V_{DRAIN} = 120$ V, $F_{OSC} = 60$ kHz			2.5	mA
		$V_{DRAIN} = 120$ V, $F_{OSC} = 115$ kHz			3.5	mA
$I_{DD\_FAULT}$	Operating supply current, with protection tripping	$V_{DD} = 10$ V			400	µA
$I_{DD\_OFF}$	Operating supply current with $V_{DD} < V_{DD\_OFF}$	$V_{DD} = 7$ V			270	µA



Table 9. Controller section

Symbol	Parameter	Test condition	Min	Typ	Max	Unit
<b>Feed-back pin</b>						
$V_{FBolp}$	Overload shutdown threshold		4.5	4.8	5.2	V
$V_{FBlin}$	Overload detection threshold		3.2	3.5	3.7	V
$V_{FBbm}$	Burst mode threshold	Voltage falling	0.54	0.6	0.66	V
$V_{FBbmhys}$	Burst mode hysteresis	Voltage rising		100		mV
$I_{FB1}$	Feedback sourced current	$V_{FB} = 0.3\text{ V}$	-150	-200	-280	uA
$I_{FB2}$	Feedback current-OLP delay	$V_{FBlin} < V_{FB} < V_{FBolp}$		-3		uA
$R_{FB(DYN)}$	Dynamic resistance	$V_{FB} < 3.3\text{ V}$	14		20	k $\Omega$
$H_{FB}$	$\Delta V_{FB} / \Delta I_D$	(1) $T_J = 25\text{ }^\circ\text{C}$	2		6	V/A
<b>CONT pin</b>						
$V_{CONT\_l}$	Low-level clamp voltage	$I_{CONT} = -100\text{ }\mu\text{A}$	0.4	0.5	0.6	V
$V_{CONT\_h}$	High-level clamp voltage	$I_{CONT} = 1\text{ mA}$	5	5.5	6	V
<b>Current limitation</b>						
$I_{Dim}$	Max drain current limitation	$V_{FB} = 4\text{ V}$ , $I_{CONT} = -10\text{ }\mu\text{A}$ $T_J = 25\text{ }^\circ\text{C}$	0.75	0.80	0.85	A
$t_{SS}$	Soft-start time		7.6	8.5	9.4	ms
$T_{ON\_MIN}$	Minimum turn-on time		220	370	480	ns
$t_d$	Propagation delay			100		ns
$t_{LEB}$	Leading edge blanking	(1)		300		ns
$I_{D\_BM}$	Peak drain current during burst mode	$V_{FB} = 0.6\text{ V}$		160		mA
<b>Oscillator section</b>						
$F_{OSC}$	$V_{FB} = 1\text{ V}$	VIPER28L	54	60	66	kHz
		VIPER28H	103	115	127	kHz
FD	Modulation depth	VIPER28L		$\pm 4$		kHz
		VIPER28H		$\pm 8$		kHz
FM	Modulation frequency		200	250	300	Hz
$D_{MAX}$	Maximum duty cycle		70		80	%
<b>Overcurrent protection (2<sup>nd</sup> OCP)</b>						
$I_{DMAX}$	Second overcurrent threshold	(1)		1.2		A
<b>Overvoltage protection</b>						
$V_{OVP}$	Overvoltage protection threshold		2.7	3	3.3	V

Table 9. Controller section (continued)

Symbol	Parameter	Test condition	Min	Typ	Max	Unit
$t_{STROBE}$	Overvoltage protection strobe time			2.2		$\mu s$
<b>Extra power management</b>						
$I_{DLIM\_EPT}$	Drain current limit with EPT function	(1)		85% $I_{Dlim}$		A
$V_{EPT(STOP)}$	EPT shutdown threshold	$I_{CONT} < -10 \mu A$	3.6	4	4.4	V
$V_{EPT(RESTART)}$	EPT restart threshold		0.4	0.6	0.8	V
$I_{EPT}$	Sink/source current		4	5	6	$\mu A$
<b>Thermal shutdown</b>						
$T_{SD}$	Thermal shutdown temperature	(1)	150	160		$^{\circ}C$
$T_{HYST}$	Thermal shutdown hysteresis	(1)		30		$^{\circ}C$

1. Specification guaranteed by characterization.

Figure 4. Minimum turn-on time test circuit

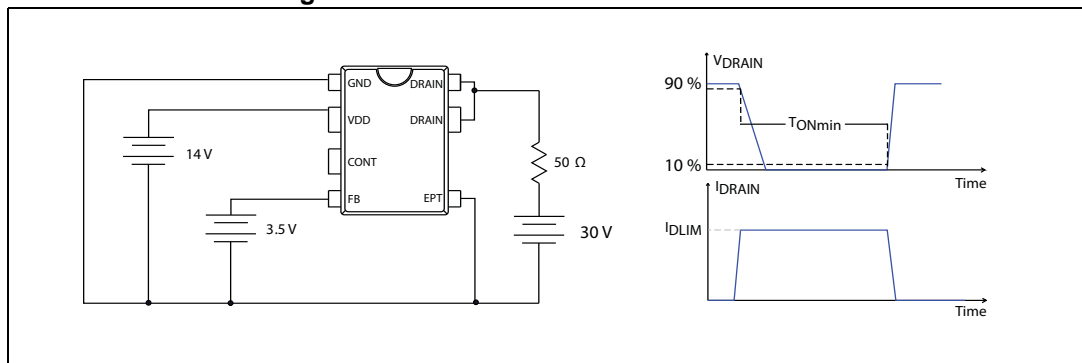
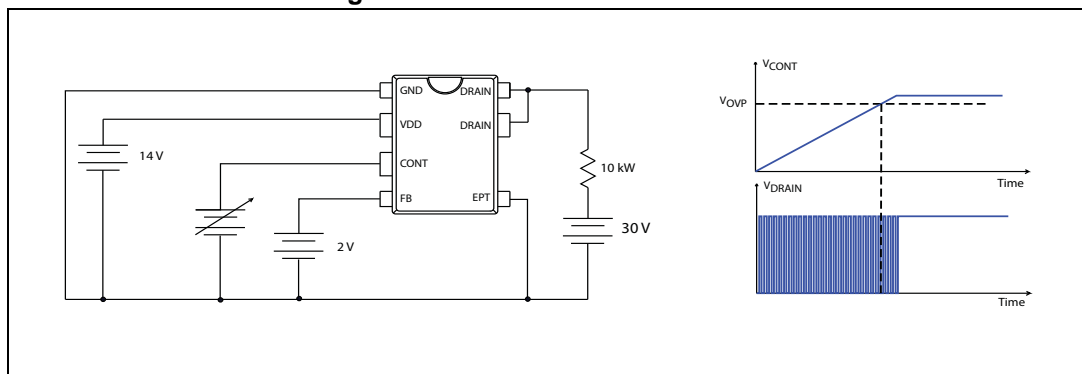
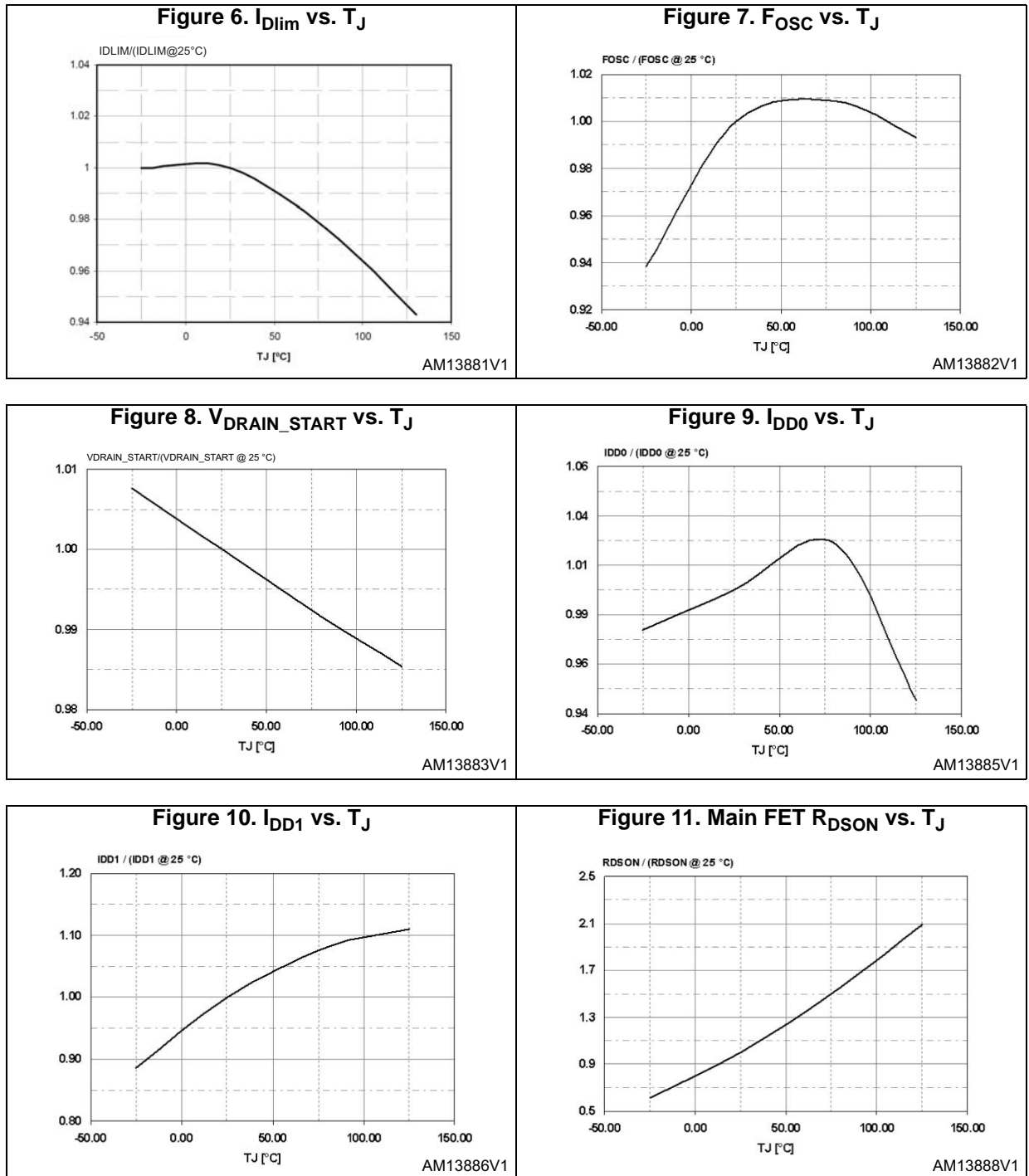


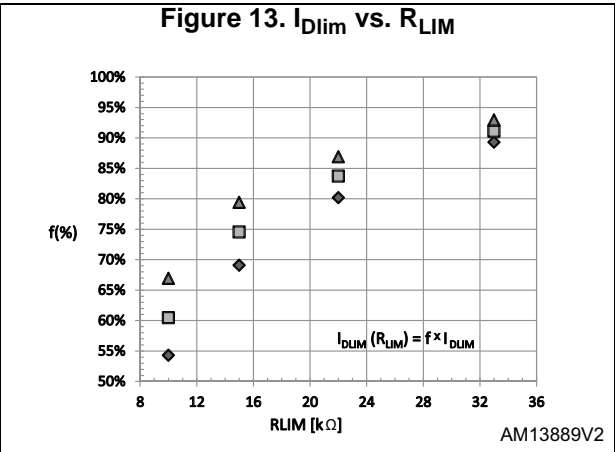
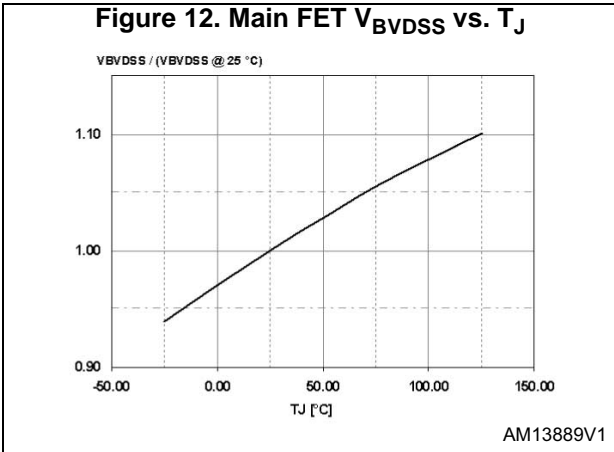
Figure 5. OVP threshold test circuit



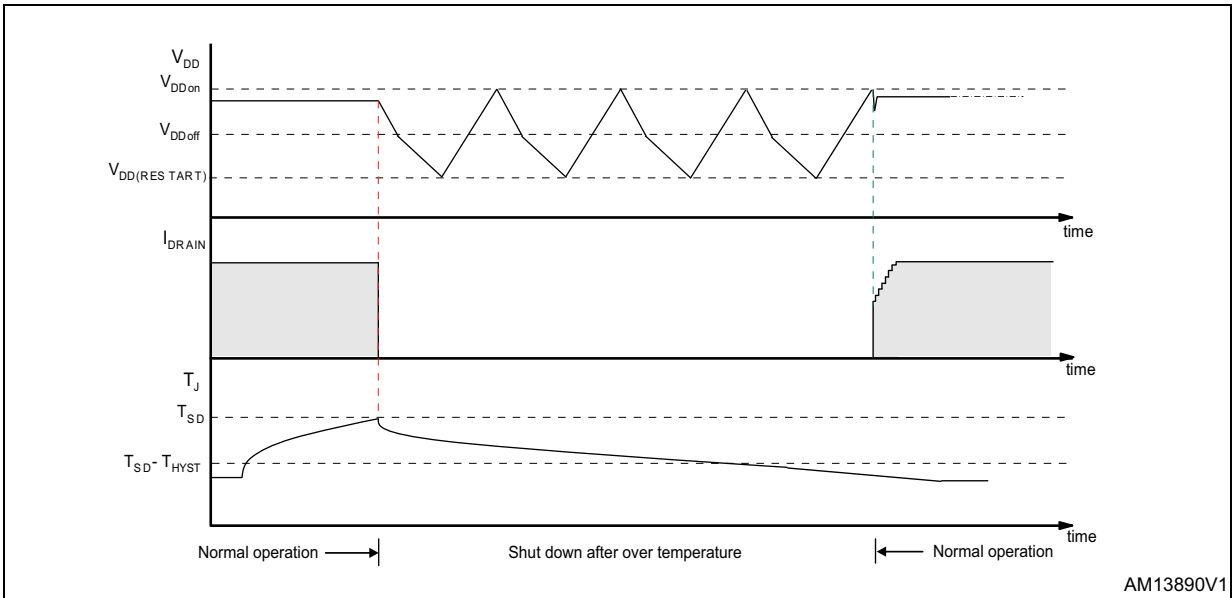
Note: Adjust  $V_{DD}$  above  $V_{DDon}$  startup threshold before setting to 14 V.

# 5 Typical electrical characteristics



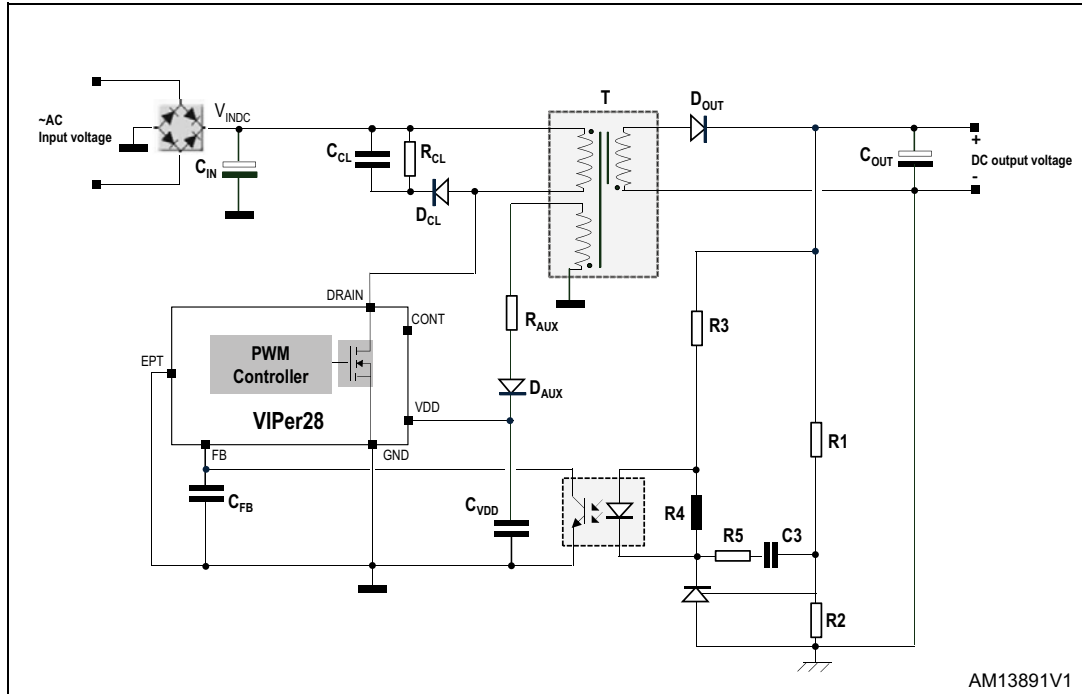


**Figure 14. Thermal shutdown**



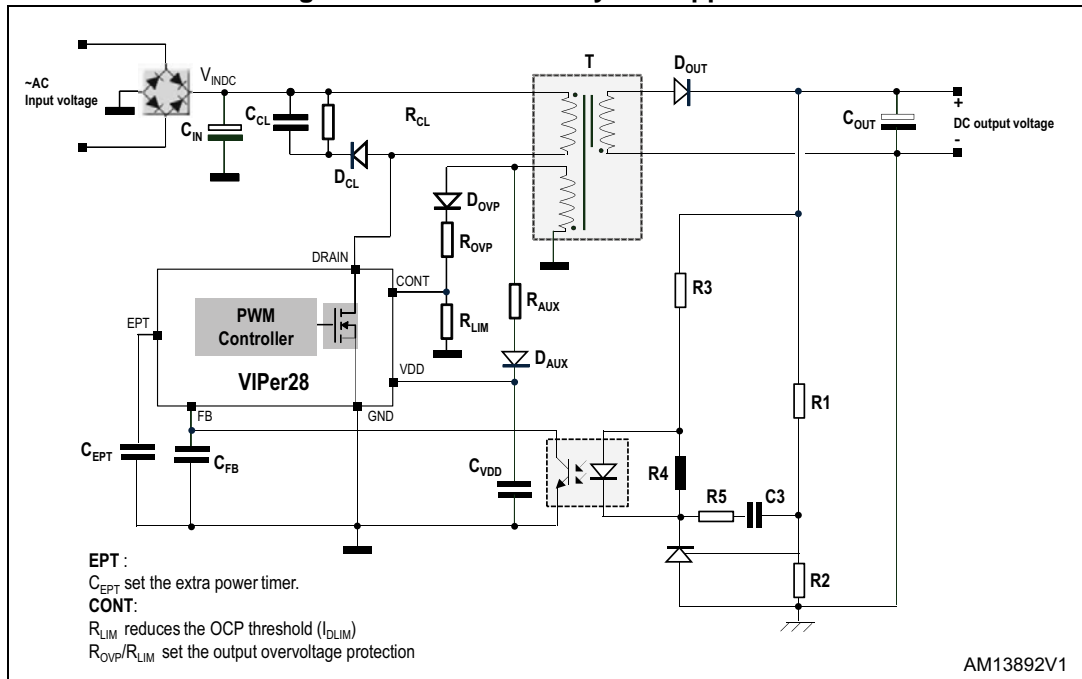
# 6 Typical circuit

Figure 15. Basic flyback application



AM13891V1

Figure 16. Full-featured flyback application



AM13892V1

## 7 Operation

The device is a high-performance low-voltage PWM controller chip with an 800 V, avalanche rugged power section.

The controller includes the oscillator with jitter, startup circuit with soft-start, PWM logic, current limiting circuit with adjustable setpoint, second overcurrent circuit, burst mode management, Extra Power Timer circuit, UVLO circuit, auto-restart circuit and thermal protection circuit.

The current limit setpoint is set by the CONT pin. Burst mode operation guarantees high performance in standby mode and contributes to meeting energy-saving standards.

All the fault protections are built in auto-restart mode with very low repetition rate to prevent the IC from overheating.

### 7.1 Power section and gate driver

The power section is implemented with an avalanche-rugged N-channel MOSFET, which guarantees safe operation within the specified energy rating as well as high dv/dt capability. The power section has a  $B_{V_{DS}}$  of 800 V min. and a maximum  $R_{DS(on)}$  of 7  $\Omega$  at 25 °C.

The integrated SenseFET structure allows a virtually loss-less current sensing.

The gate driver is designed to supply a controlled gate current during both turn-on and turn-off in order to minimize common-mode EMI. Under UVLO conditions an internal pull-down circuit holds the gate low in order to ensure that the power section cannot be turned on accidentally.

### 7.2 High-voltage startup generator

The HV current generator is supplied through the DRAIN pin and it is enabled only if the input bulk capacitor voltage is higher than the  $V_{DRAIN\_START}$  threshold, 80 V DC typically. When the HV current generator is ON, the  $I_{DDch1}$  current (3 mA typical value) is delivered to the capacitor on the  $V_{DD}$  pin. During auto-restart mode after a fault event, the current is reduced to  $I_{DDch2}$  (0.6 mA, typ) in order to have a slow duty cycle during the restart phase.

### 7.3 Power-up and soft startup

When the input voltage rises to the device start threshold,  $V_{DRAIN\_START}$ , the VDD voltage begins to grow due to the  $I_{DDch1}$  current (see [Table 8: Supply section](#)) coming from the internal high-voltage startup circuit. If the VDD voltage reaches the  $V_{DDon}$  threshold, the power MOSFET starts switching and the HV current generator is turned OFF.

The IC is powered by the energy stored in the capacitor on the VDD pin,  $C_{VDD}$ , until the self-supply circuit (typically an auxiliary winding of the transformer and a steering diode) develops a voltage high enough to sustain the operation.

The  $C_{VDD}$  capacitor must be correctly sized to avoid fast discharge and keep the required voltage higher than the  $V_{DDoff}$  threshold. In fact, an insufficient capacitance value could terminate the switching operation before the controller receives any energy from the auxiliary winding.

The following formula can be used for the  $C_{VDD}$  capacitor calculation:

**Equation 1**

$$C_{VDD} = \frac{I_{DDch1} \times t_{SSaux}}{V_{DDon} - V_{DDoff}}$$

The parameter  $t_{SSaux}$  is the time needed for the steady state of the auxiliary voltage. This time represents an estimate of the user's application according to the output stage configurations (transformer, output capacitances, etc.).

During the converter startup time, the drain current limitation is progressively increased to the maximum value. In this way the stress on the secondary diode is considerably reduced. It also helps to prevent transformer saturation. The soft-start time lasts 8.5 ms and the feature is implemented for every attempt of the startup converter or after a fault.

**Figure 17.  $I_{DD}$  current during startup and burst mode**

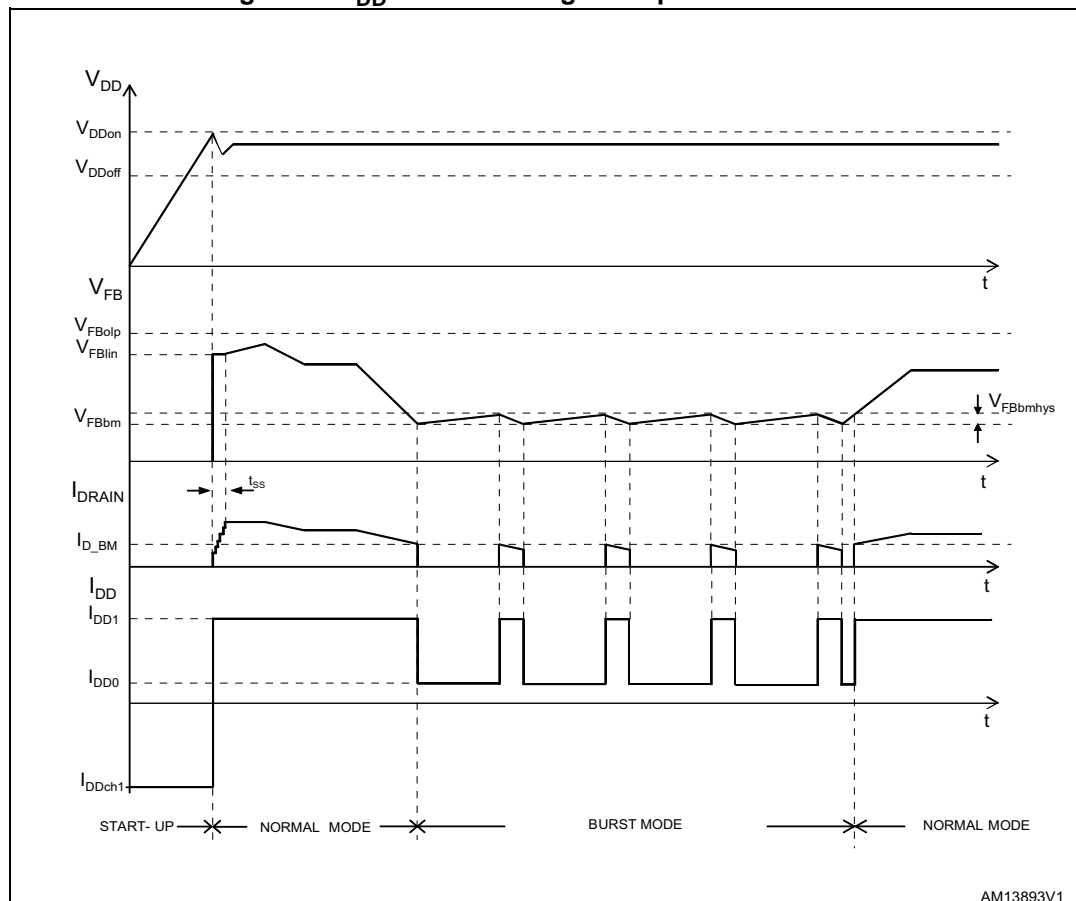


Figure 18. Timing diagram: normal power-up and power-down sequences

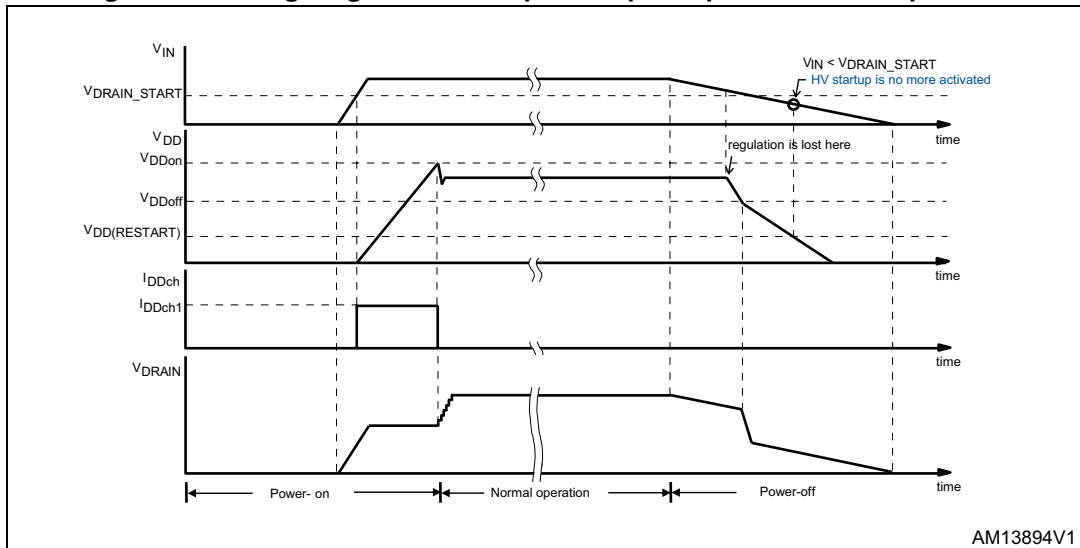
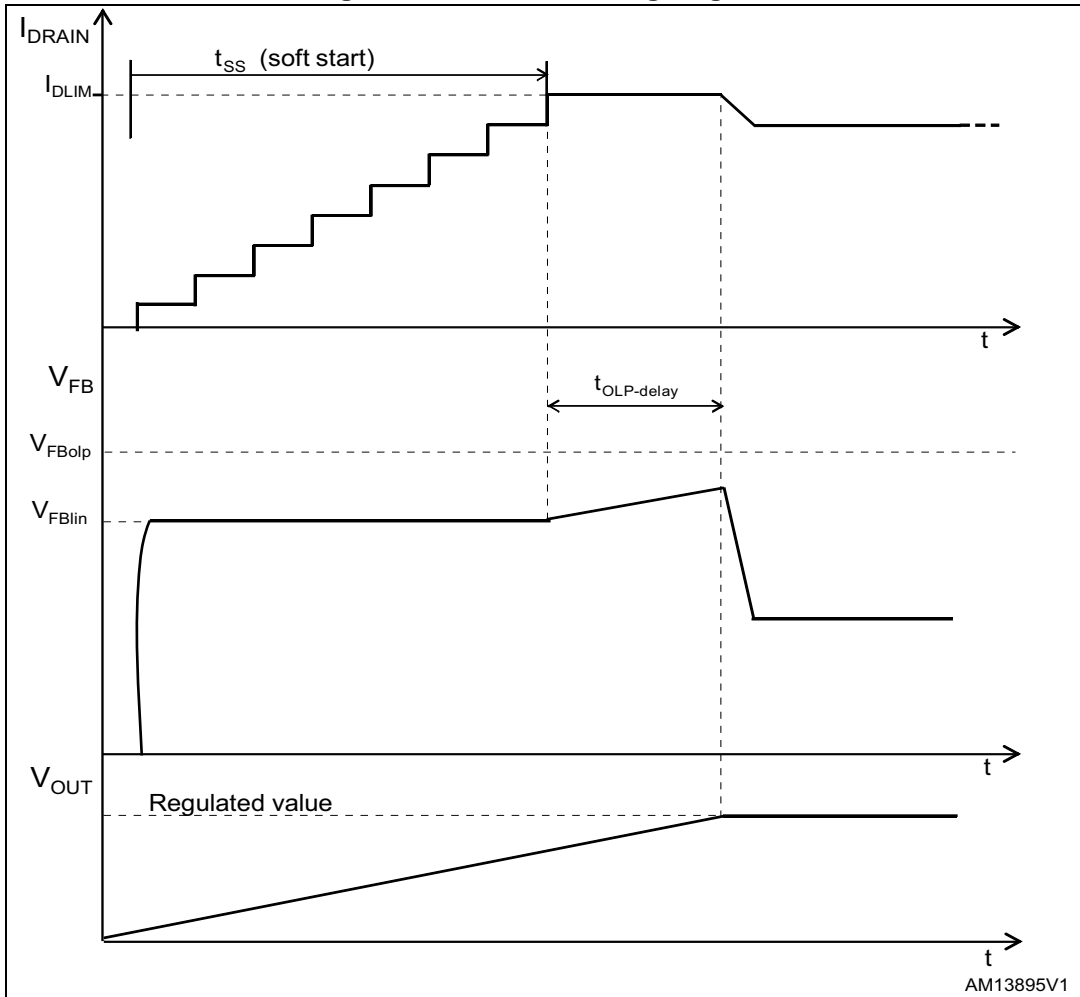


Figure 19. Soft-start: timing diagram





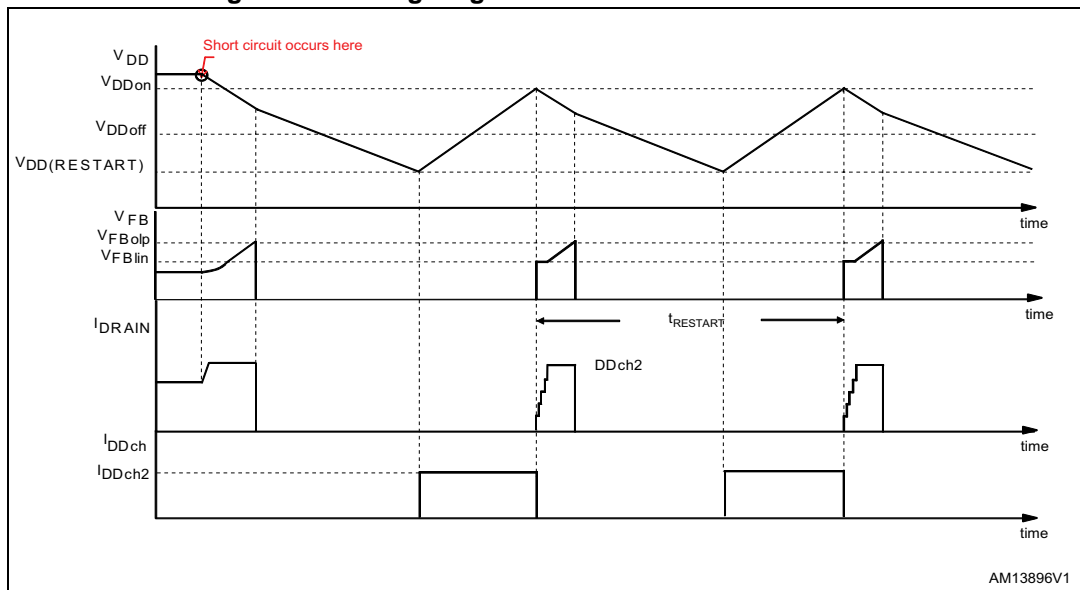
## 7.4 Power-down

At converter power-down, the system loses its ability to regulate as soon as the decreasing input voltage is low enough for the peak current limitation to be reached. The VDD voltage drops and when it falls below the  $V_{DDoff}$  threshold (see [Table 8: Supply section](#)) the power MOSFET is switched OFF, the energy transfers to the IC is interrupted and, consequently, the VDD voltage decreases ([Table 19: Soft-start: timing diagram](#)), the startup sequence is inhibited and the power-down is completed. This feature is useful as it prevents the converter from attempting a restart and ensures monotonic output voltage decay during system power-down.

## 7.5 Auto-restart

Every time a protection is tripped, the IC is automatically restarted after a duration that depends on the discharge and recharge of the  $C_{VDD}$  capacitor. As shown in [Figure 20](#), after a fault the IC is stopped and, consequently, the  $V_{DD}$  voltage decreases because of the IC's consumption. As soon as the  $V_{DD}$  voltage falls below the threshold  $V_{DD(RESTART)}$  and if the DC input voltage is higher than  $V_{DRAIN\_START}$  threshold, the internal HV current source is turned ON and it starts to charge the  $C_{VDD}$  capacitor with the current  $I_{DDch2}$  (0.6 mA, typ). As soon as the  $V_{DD}$  voltage reaches the threshold  $V_{DD(ON)}$ , the IC restarts.

Figure 20. Timing diagram: behavior after short-circuit



AM13896V1

## 7.6 Oscillator

The switching frequency is internally fixed to 60 kHz or 115 kHz. In both cases the switching frequency is modulated by approximately  $\pm 4$  kHz (60 kHz version) or  $\pm 8$  kHz (115 kHz version) at 250 Hz (typical) rate, so that the resulting spread-spectrum action distributes the energy of each harmonic of the switching frequency over a number of side-band harmonics having the same energy on the whole, but smaller amplitudes.

## 7.7 Current mode conversion with adjustable current limit setpoint

The device is a current mode converter. The drain current is sensed and converted to voltage that is applied to the non-inverting pin of the PWM comparator. This voltage is compared with the one on the feedback pin through a voltage divider on a cycle-by-cycle basis.

The device has a default current limit value,  $I_{Dlim}$ , that can be adjusted according to the electrical specification, by the  $R_{LIM}$  resistor connected to the CONT pin.

The CONT pin has a minimum current sunk needed to activate the  $I_{Dlim}$  adjustment. Without  $R_{LIM}$  or with high  $R_{LIM}$  (i.e. 100 k $\Omega$ ) the current limit is set to the default value (see  $I_{Dlim}$ , [Table 9: Controller section](#)).

## 7.8 Overvoltage protection (OVP)

The device has integrated logic for the monitoring of the output voltage using as an input signal the voltage  $V_{CONT}$  during the OFF time of the power MOSFET. This is the time when the voltage from the auxiliary winding tracks the output voltage, through the turn ratio.

The CONT pin has to be connected to the auxiliary winding through the diode  $D_{OVP}$  and the resistors  $R_{OVP}$  and  $R_{LIM}$  as shown in [Figure 22: CONT pin configuration](#). When, during the OFF time, the voltage  $V_{CONT}$  exceeds four consecutive times the reference voltage  $V_{OVP}$  (see [Table 9: Controller section](#)), the overvoltage protection will stop the power MOSFET and the converter enters auto-restart mode.

In order to bypass the noise immediately after the turn-off of the power MOSFET, the voltage  $V_{CONT}$  is sampled inside a short window after the time  $T_{STROBE}$ , see [Table 9: Controller section](#) and the [Figure 21: OVP timing diagram](#). The sampled signal, if higher than  $V_{OVP}$ , triggers the internal OVP digital signal and increments the internal counter. The same counter is reset every time the signal OVP is not triggered in one oscillator cycle.

Referring to [Figure 22: CONT pin configuration](#), the resistor divider ratio  $k_{OVP}$  will be given by:

### Equation 2

$$k_{OVP} = \frac{V_{OVP}}{\frac{N_{AUX}}{N_{SEC}} \cdot (V_{OUTOVP} + V_{DSEC}) - V_{DAUX}}$$

**Equation 3**

$$k_{OVP} = \frac{R_{LIM}}{R_{LIM} + R_{OVP}}$$

Where:

- $V_{OVP}$  is the OVP threshold (see [Table 9: Controller section](#))
- $V_{OUT\ OVP}$  is the converter output voltage value to activate the OVP set by the designer
- $N_{AUX}$  is the number of the auxiliary winding turns
- $N_{SEC}$  is the number of the secondary winding turns
- $V_{DSEC}$  is the secondary diode forward voltage
- $V_{DAUX}$  is the auxiliary diode forward voltage
- $R_{OVP}$  together with  $R_{LIM}$  constitute the output voltage divider

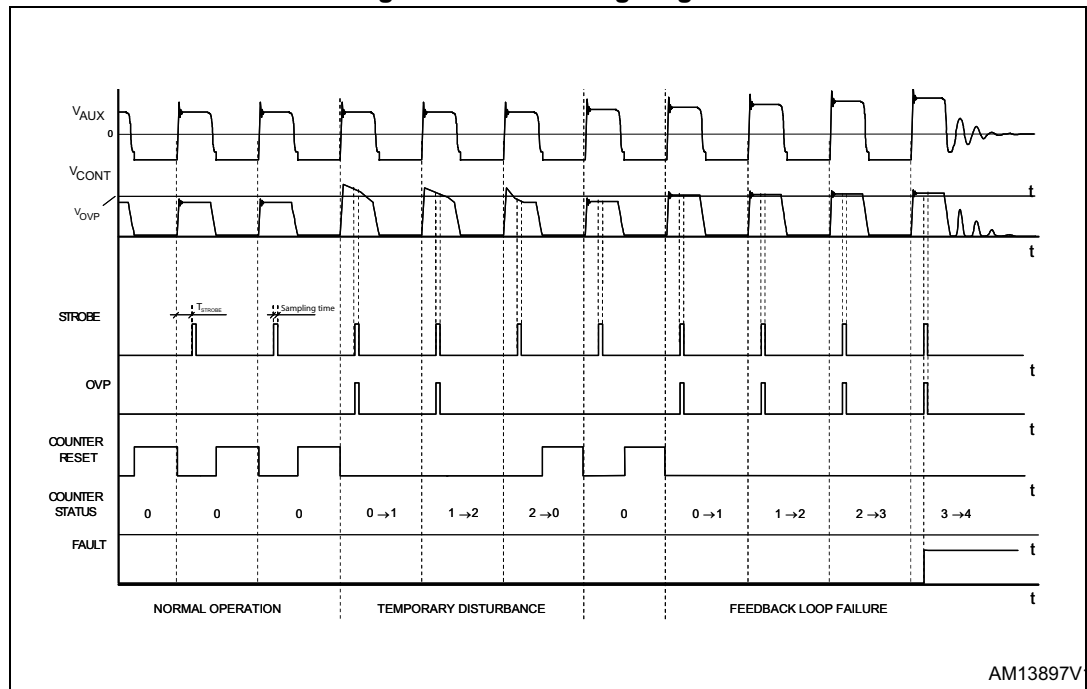
Then, fixing  $R_{LIM}$  according to the desired  $I_{Dim}$ , the  $R_{OVP}$  can be calculated by:

**Equation 4**

$$R_{OVP} = R_{LIM} \times \frac{1 - k_{OVP}}{k_{OVP}}$$

The resistor values will be such that the current sourced and sunk by the CONT pin are within the rated capability of the internal clamp.

**Figure 21. OVP timing diagram**



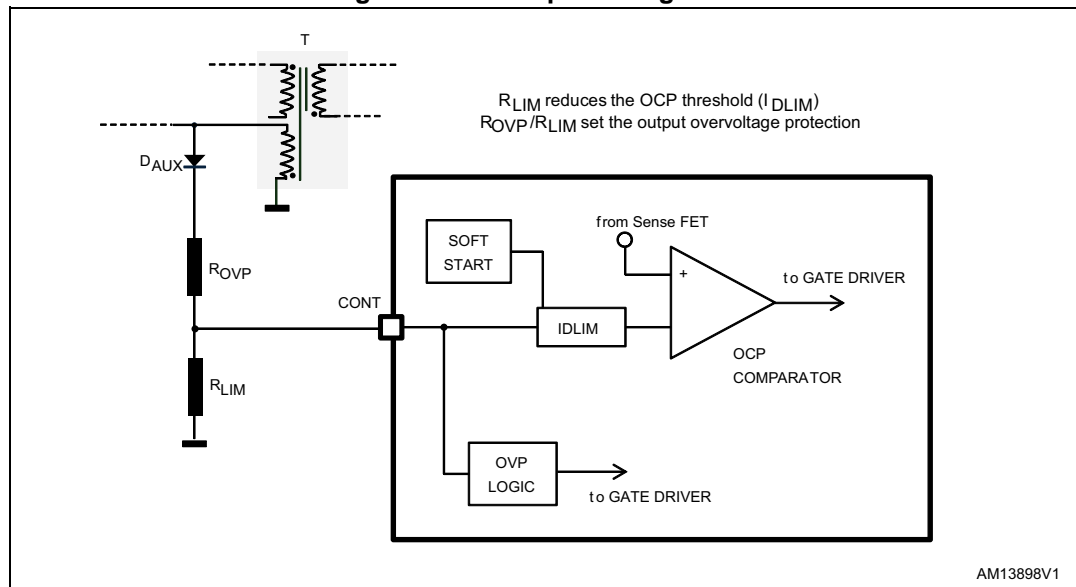
## 7.9 About CONT pin

Referring to [Figure 22](#), the CONT pin is used to configure the:

1. reduction of the OCP setpoint ( $I_{DLIM}$ )
2. output overvoltage protection (OVP)

[Table 10](#) lists the external components needed to activate one or more of the CONT pin functions.

**Figure 22. CONT pin configuration**



**Table 10. CONT pin configurations**

Function / component	$R_{LIM}$	$R_{OVP}$	$D_{AUX}$
$I_{DLIM}$ reduction	See <a href="#">Figure 13</a>	No	No
OVP	$\geq 80 \text{ k}\Omega$	See <a href="#">Equation 4</a>	Yes
$I_{DLIM}$ reduction and OVP <sup>(1)</sup>	See <a href="#">Figure 13</a>	See <a href="#">Equation 4</a>	Yes

1. Select  $R_{LIM}$  then  $R_{OVP}$ .

## 7.10 Feedback and overload protection (OLP)

The device is a current-mode converter. The feedback pin controls PWM operation as well as burst mode and activates the overload protection. [Figure 23: FB pin configuration \(option 1\)](#) and [Figure 24: FB pin configuration \(option 2\)](#) show the internal current-mode structure.

With the feedback pin voltage between  $V_{FBbm}$  and  $V_{FBlin}$ , (see [Table 9: Controller section](#)) the drain current is sensed and converted to voltage that is applied to the non-inverting pin of the PWM comparator.

This voltage is compared to the voltage on the feedback pin through a voltage divider on a cycle-by-cycle basis. When these two voltages are equal, the PWM logic orders the switch-off of the power MOSFET. The drain current is always limited to the value of  $I_{DLIM}$ .

When the feedback pin voltage reaches the threshold  $V_{FBlin}$ , an internal current generator starts to charge the feedback capacitor ( $C_{FB}$ ) and when the feedback voltage reaches the  $V_{FBolp}$  threshold, the converter is turned off and the automatic restart is activated.

During startup, when the output voltage is still low, if the feedback network is not properly dimensioned, the feedback voltage could rise up to the overload threshold ( $V_{FBolp}$ ) generating the switching off of the IC itself. Taking into account that the feedback network also fixes the loop stability, two options can be considered for this network.

The time from the overload detection ( $V_{FB} = V_{FBlin}$ ) to the device shutdown ( $V_{FB} = V_{FBolp}$ ) must be set by  $C_{FB}$  (or  $C_{FB1}$ ) using the formula:

#### Equation 5

$$T_{OLP-delay} = C_{FB} \times \frac{V_{FBolp} - V_{FBlin}}{I_{FB2}}$$

In the option 1 shown in [Figure 23: FB pin configuration \(option 1\)](#), the capacitor  $C_{FB}$  has a dual function: guaranteeing the loop compensation and fixing the overload delay time as calculated in [Equation 5](#).

Owing to the above considerations, the OLP delay time must be long enough to bypass the initial output voltage transient and check the overload condition only when the output voltage is in steady state. The output transient time depends on the value of the output capacitor and on the load.

When the value of the  $C_{FB}$  capacitor calculated for the loop stability is too low and cannot ensure enough OLP delay, an alternative compensation network can be used and it is shown in [Figure 24: FB pin configuration \(option 2\)](#).

Using this alternative compensation network, two poles ( $f_{PFB}$ ,  $f_{PFB1}$ ) and one zero ( $f_{ZFB}$ ) are introduced by the capacitors  $C_{FB}$  and  $C_{FB1}$  and the resistor  $R_{FB1}$ .

The capacitor  $C_{FB}$  introduces a pole ( $f_{PFB}$ ) at higher frequency than  $f_{ZB}$  and  $f_{PFB1}$ . This pole is usually used to compensate the high-frequency zero due to the ESR (equivalent series resistor) of the output capacitance of the flyback converter.

The mathematical expressions of these poles and zero frequency are:

$$f_{ZFB} = \frac{1}{2 \cdot \pi \cdot C_{FB1} \cdot R_{FB1}}$$

#### Equation 6

$$f_{PFB} = \frac{R_{FB(DYN)} + R_{FB1}}{2 \cdot \pi \cdot C_{FB} \cdot (R_{FB(DYN)} \cdot R_{FB1})}$$

#### Equation 7

$$f_{PFB1} = \frac{1}{2 \cdot \pi \cdot C_{FB1} \cdot (R_{FB1} + R_{FB(DYN)})}$$

The  $R_{FB(DYN)}$  is the dynamic resistance seen by the FB pin.

The  $C_{FB1}$  capacitor fixes the OLP delay and usually  $C_{FB1}$  results in a much higher value than  $C_{FB}$ . Equation 5 can be still used to calculate the OLP delay, but  $C_{FB1}$  has to be considered instead of  $C_{FB}$ . Using the compensation network shown in option 2, in all cases the loop stability can be set as well as a sufficient OLP delay.

Figure 23. FB pin configuration (option 1)

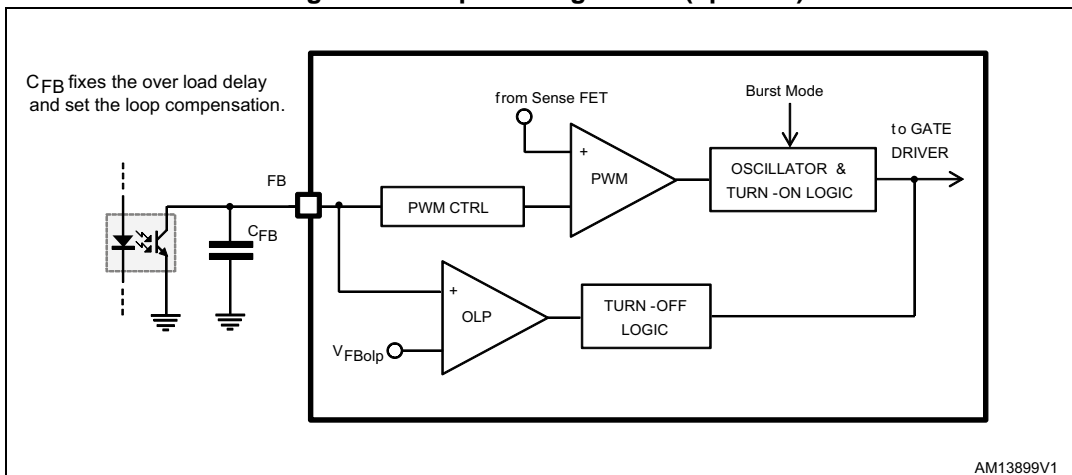
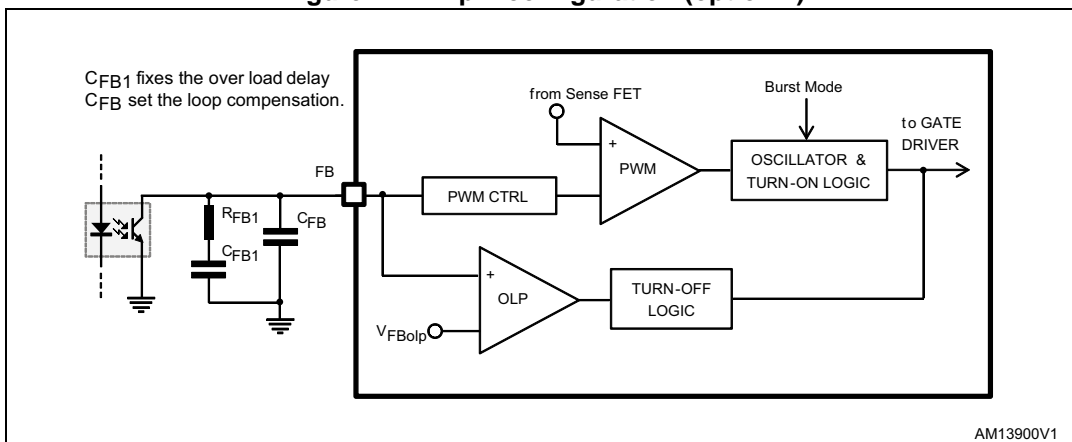


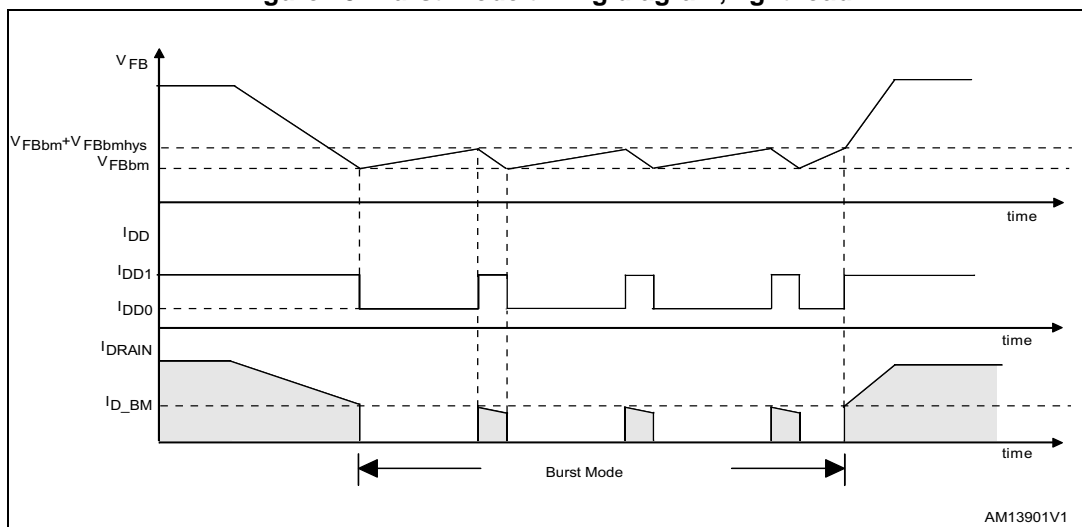
Figure 24. FB pin configuration (option 2)



## 7.11 Burst-mode operation at no load or very light load

When the load decreases, the feedback loop reacts by lowering the feedback pin voltage. If it falls below the burst mode threshold,  $V_{FBbm}$ , the power MOSFET is no longer allowed to be switched on. After the MOSFET stops, the feedback pin voltage increases and when it exceeds the level,  $V_{FBbm} + V_{FBbmhys}$ , the power MOSFET starts switching again. The burst mode thresholds are provided in [Table 9: Controller section](#) and [Figure 25: Burst mode timing diagram, light load](#) shows this behavior. The system alternates between a period of time where the power MOSFET is switching to a period of time where the power MOSFET is not switching. This mode of operation is the burst mode. The advantage of burst mode operation is an average switching frequency much lower than the normal operation frequency, up to several hundred hertz, minimizing all frequency-related losses. In order to prevent audible noise, during burst mode the drain current peak is clamped to the level,  $I_{D\_BM}$ , given in [Table 9: Controller section](#).

**Figure 25. Burst mode timing diagram, light load**



### 7.12 Extra power timer (EPT)

The extra power timer feature allows the setting of a blanking time inside which an overload current can be admitted.

The timer is set through a capacitor ( $C_{EPT}$ ) connected to the EPT pin. Its duration is in the range of a few seconds and is limited by thermal constraints.

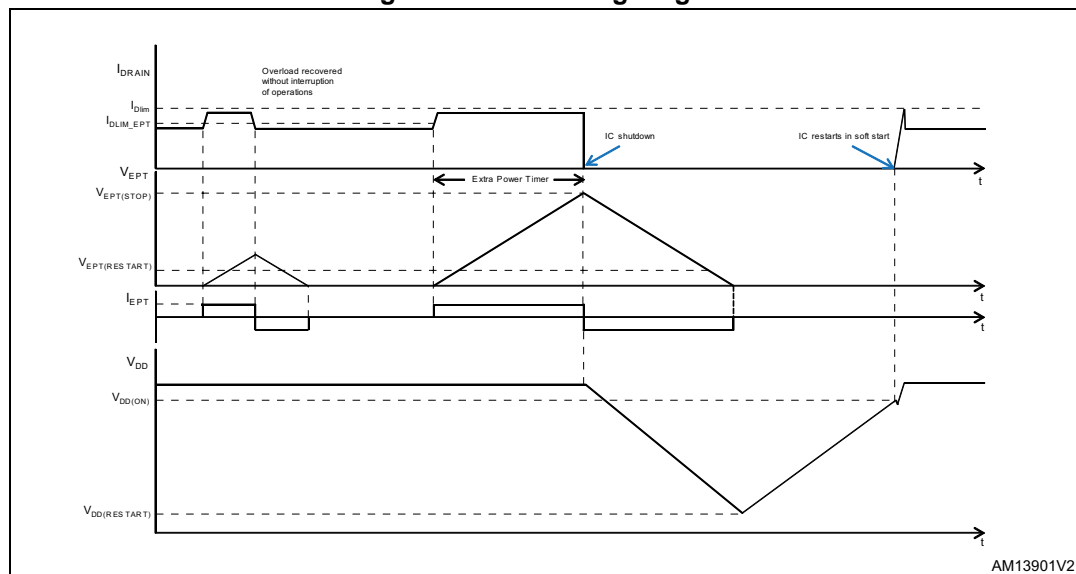
The extra power timer (EPT) is started as soon as the drain current reaches the threshold  $I_{DLIM\_EPT}$  (typ. 85% of  $I_{Dlim}$ ) and its duration is defined by the time needed to charge the capacitor  $C_{EPT}$  up to the value  $V_{EPT(STOP)}$  (4V, typ). The charging current is  $I_{EPT}$  (5 uA, typ).

If the EPT starts, the IC sustains the overload and continues to operate normally if the drain current falls below the threshold  $I_{DLIM\_EPT}$  (85% of  $I_{Dlim}$ ) before the EPT voltage reaches the value  $V_{EPT(STOP)}$ . The capacitor  $C_{EPT}$  is discharged through the current  $I_{EPT}$  (5 uA, typ) and the next EPT is inhibited until the EPT voltage is higher than  $V_{EPT(RESTART)}$  (0.6 V, typ).

If the EPT starts and the EPT voltage reaches the value  $V_{EPT(STOP)}$ , the IC stops and it is automatically restarted. The  $C_{VDD}$  capacitor is then discharged down to the value  $V_{DD(RESTART)}$  (4.5 V, typ) and is recharged, through the HV current source, up to the value  $V_{DD(on)}$  (14 V, typ). Also in this case the capacitor  $C_{EPT}$  is discharged through the  $I_{EPT}$  current. See [Figure 26](#) and [Table 8: Supply section](#).

The EPT pin has to be connected to GND if the function is not used.

Figure 26. EPT timing diagram





## 7.13 2<sup>nd</sup> level overcurrent protection and hiccup mode

The device is protected against short-circuit of the secondary rectifier, short-circuit on the secondary winding or a hard-saturation of the flyback transformer. This type of anomalous condition is invoked when the drain current exceeds the threshold  $I_{D\text{MAX}}$ , see [Table 9: Controller section](#).

To distinguish a real malfunction from a disturbance (e.g. induced during ESD tests) a “warning state” is entered after the first signal is tripped. If, in the subsequent switching cycles, the signal is not tripped, a temporary disturbance is assumed and the protection logic will be reset in its idle state; otherwise if the  $I_{D\text{MAX}}$  threshold is exceeded for two consecutive switching cycles, a real malfunction is assumed and the power MOSFET is turned OFF.

The shutdown condition is latched as long as the device is supplied. While it is disabled, no energy is transferred from the auxiliary winding, hence the voltage on the  $C_{V\text{DD}}$  capacitor decays until the  $V_{\text{DD}}$  undervoltage threshold ( $V_{\text{DDoff}}$ ), which clears the latch.

The startup HV current generator is still off, until the  $V_{\text{DD}}$  voltage falls below its restart voltage,  $V_{\text{DD(RESTART)}}$ . After this condition the  $C_{V\text{DD}}$  capacitor is charged again by the  $I_{\text{DDch2}}$  current, and the converter switching restarts if  $V_{\text{DDon}}$  occurs. If the fault condition is not removed, the device enters auto-restart mode. This behavior results in a low-frequency intermittent operation (hiccup-mode operation), with very low stress on the power circuit.

## 8 Package mechanical data

In order to meet environmental requirements, ST offers these devices in different grades of ECOPACK<sup>®</sup> packages, depending on their level of environmental compliance. ECOPACK<sup>®</sup> specifications, grade definitions and product status are available at: [www.st.com](http://www.st.com). ECOPACK<sup>®</sup> is an ST trademark.

### 8.1 DIP-7 package information

Figure 27. DIP-7 package outline

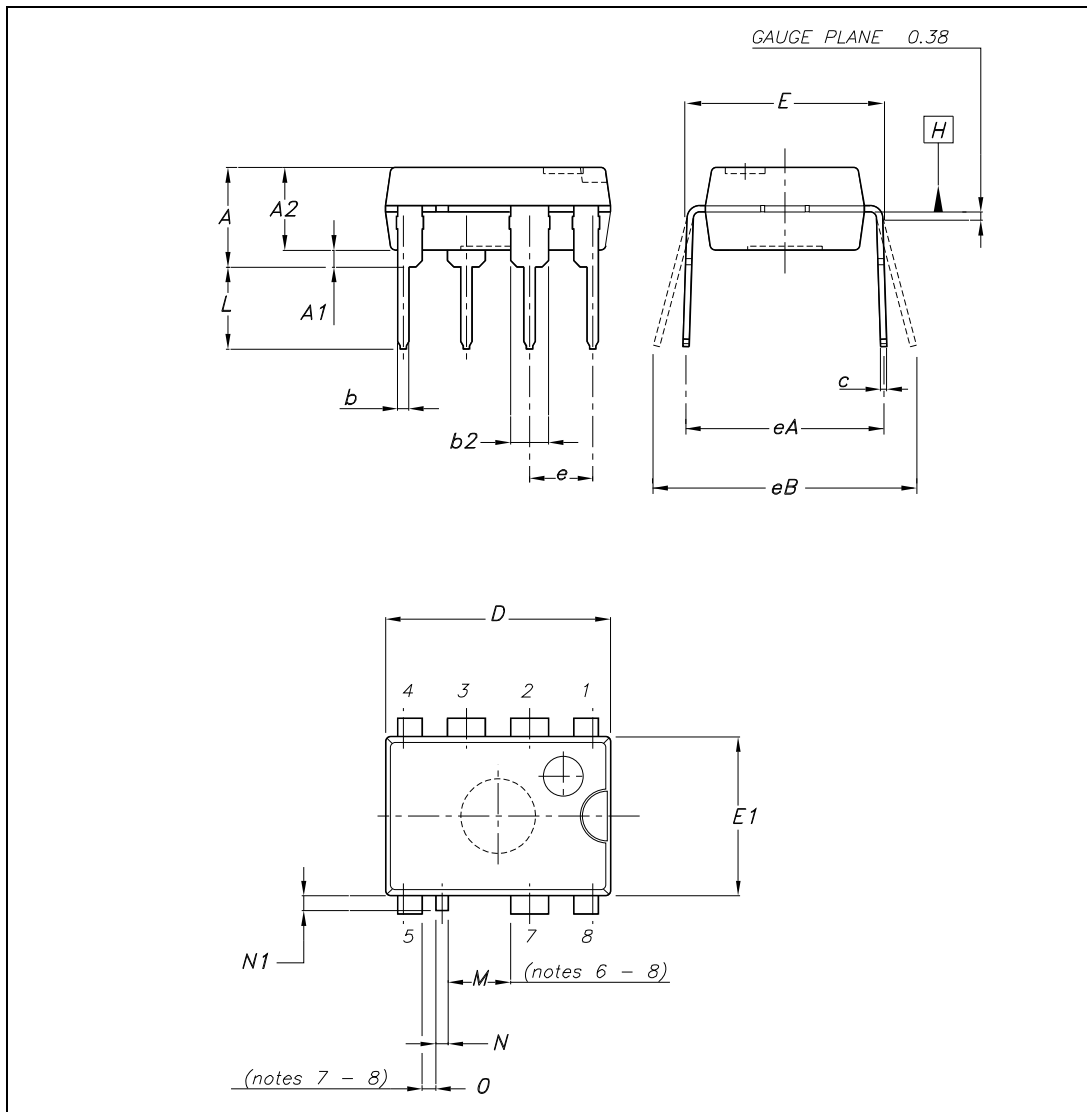


Table 11. DIP-7 mechanical data

Dim.	mm		
	Typ	Min	Max
A			5,33
A1		0,38	
A2	3,30	2,92	4,95
b	0,46	0,36	0,56
b2	1,52	1,14	1,78
c	0,25	0,20	0,36
D	9,27	9,02	10,16
E	7,87	7,62	8,26
E1	6,35	6,10	7,11
e	2,54		
eA	7,62		
eB			10,92
L	3,30	2,92	3,81
M <sup>(6)(8)</sup>	2,508		
N	0,50	0,40	0,60
N1			0,60
O <sup>(7)(8)</sup>	0,548		

## 8.2 SO16 narrow package information

Figure 28. SO16 narrow package outline

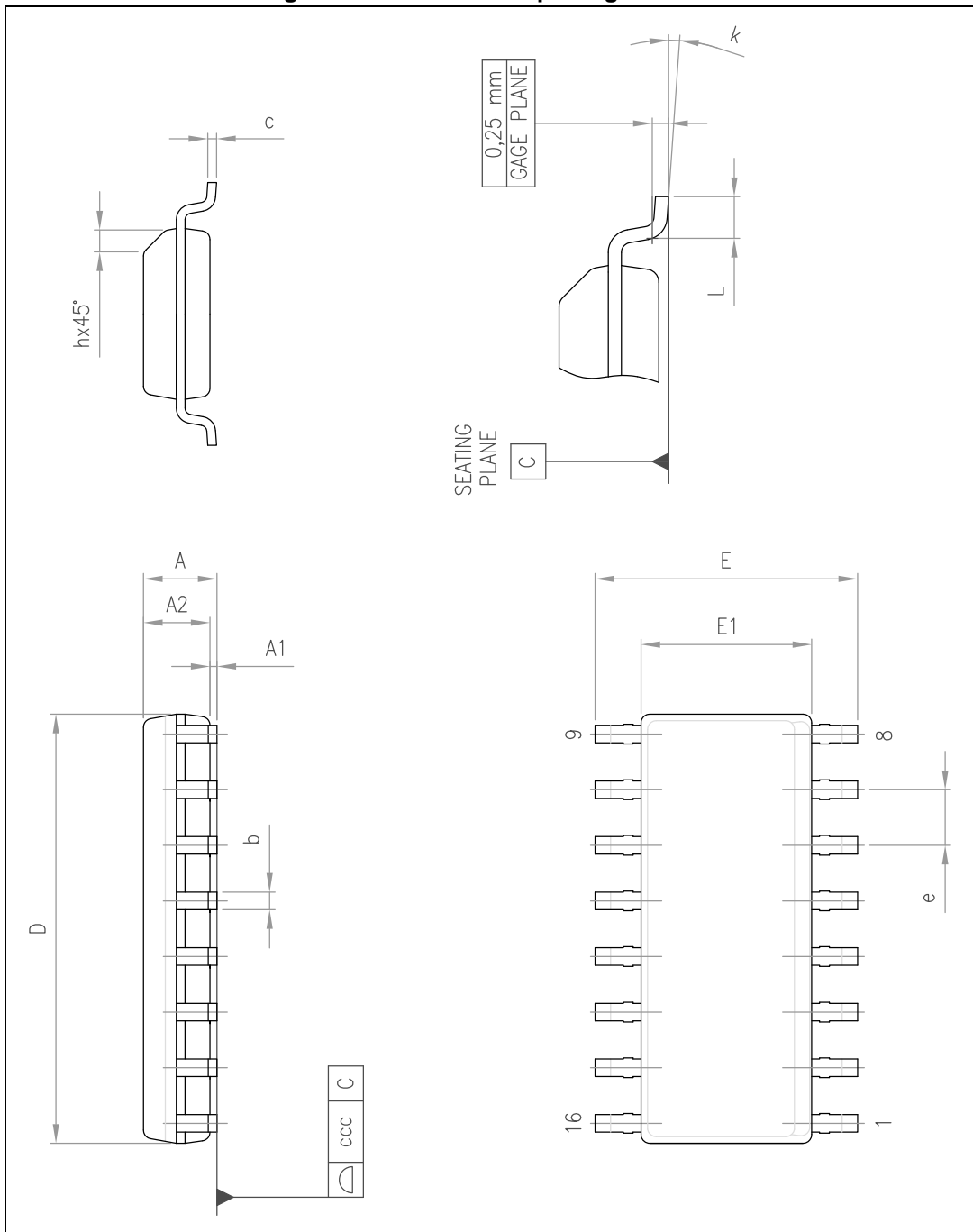


Table 12. SO16 narrow mechanical data

Dim.	mm		
	Min.	Typ.	Max.
A			1.75
A1	0.1		0.25
A2	1.25		
b	0.31		0.51
c	0.17		0.25
D	9.8	9.9	10
E	5.8	6	6.2
E1	3.8	3.9	4
e		1.27	
h	0.25		0.5
L	0.4		1.27
k	0		8
ccc			0.1

## 9 Revision history

**Table 13. Document revision history**

Date	Revision	Changes
30-Sep-2008	1	Initial release
22-Jan-2009	2	Updated <a href="#">Figure 3 on page 4</a>
21-Oct-2009	3	Added SO16N and SDIP10 packages
31-Aug-2010	4	Updated <a href="#">Figure 3</a> , <a href="#">Figure 4</a> , <a href="#">Figure 5 on page 10</a> and <a href="#">Table 3 on page 6</a>
08-Jan-2013	5	Minor text changes to improve readability in <a href="#">Chapter 7.3</a> , <a href="#">Chapter 7.4</a> , <a href="#">Chapter 7.5</a> , <a href="#">Chapter 7.7</a> , <a href="#">Chapter 7.8</a> , <a href="#">Chapter 7.9</a> , <a href="#">Chapter 7.10</a> , <a href="#">Chapter 7.11</a> , <a href="#">Chapter 7.13</a> , in <a href="#">Table 8 on page 8</a> , <a href="#">Table 9 on page 9</a> and in <a href="#">Figure 21 on page 19</a>
16-Dec-2014	6	Updated title in cover page. Removed SDIP10 package. Content reworked to improve readability.

**IMPORTANT NOTICE – PLEASE READ CAREFULLY**

STMicroelectronics NV and its subsidiaries ("ST") reserve the right to make changes, corrections, enhancements, modifications, and improvements to ST products and/or to this document at any time without notice. Purchasers should obtain the latest relevant information on ST products before placing orders. ST products are sold pursuant to ST's terms and conditions of sale in place at the time of order acknowledgement.

Purchasers are solely responsible for the choice, selection, and use of ST products and ST assumes no liability for application assistance or the design of Purchasers' products.

No license, express or implied, to any intellectual property right is granted by ST herein.

Resale of ST products with provisions different from the information set forth herein shall void any warranty granted by ST for such product.

ST and the ST logo are trademarks of ST. All other product or service names are the property of their respective owners.

Information in this document supersedes and replaces information previously supplied in any prior versions of this document.

© 2014 STMicroelectronics – All rights reserved

# Mouser Electronics

Authorized Distributor

Click to View Pricing, Inventory, Delivery & Lifecycle Information:

[STMicroelectronics:](#)

[VIPER28HDTR](#) [VIPER28LDTR](#) [VIPER28HN](#) [VIPER28LN](#) [VIPER28HE](#) [VIPER28LE](#) [VIPER28HD](#) [VIPER28LD](#)